



High efficiency air to water

Heat pumps LZT series

HidROS

THE COMPANY

HIDROS was born in 1993 as a trading company involved in the market of dehumidification and humidification of the air.

Quite soon the necessity to satisfy the great demand of special products, in a wide variety of applications and capacity, lead the company to develop and produce its own production.

Today HIDROS with its qualified staff, designs, develops and tests dehumidifying systems and air handling units based on refrigerant cycle, heat pumps and water chillers.

Hidros produces standard units with dehumidification capacities from 25 to 3000 l/24h and cooling and heating capacities from 5 to 900 kW. At this range HIDROS can add a wide range of tailor made machines to meet any customer requirement.

High competence and enthusiasm are the other essential elements that guarantee quick, flexible and adequate solutions.



LZT 92



LZT 14

WHAT IS A HEAT PUMP?

A heat pump is a machine or device that moves heat from one location (called the 'source') to another location (called the 'user'), using energy. Most heat pump technology moves heat from a low temperature source to a higher temperature user. Basically, a heat pump operates under the same principles of an air conditioner, but in the reverse way.

HOW THE HEAT PUMP WORKS

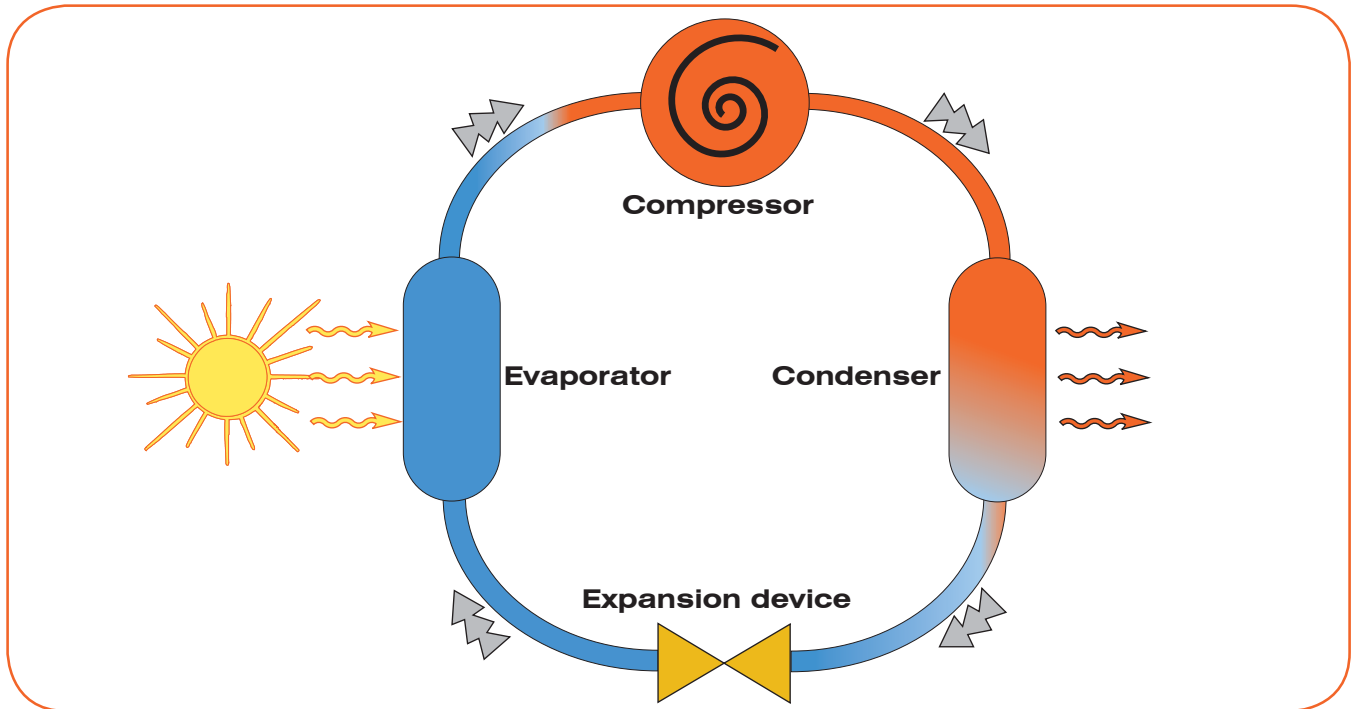

The heat pump is made by a refrigerant circuit, using a special fluid (called working fluid) that, depending on the temperature and pressure conditions in which it's working, it can be in gaseous or liquid state. The refrigerant circuit is made by:

- the compressor
- the condenser (User heat exchanger)
- the expansion valve
- the evaporator (Source heat exchanger)

The working fluid, in its gaseous state, is pressurized and circulated through the system by the compressor. On the discharge side of the compressor, the hot and highly pressurized gas is cooled in a heat exchanger, the condenser, until it condenses into a high pressure, moderate temperature liquid. The condensed refrigerant then passes through a pressure-lowering device (the expansion valve). This device then passes the low pressure, (almost) liquid refrigerant to another heat exchanger, the evaporator where the refrigerant evaporates into a gas via heat absorption. The refrigerant then returns to the compressor and the cycle is repeated. In such a system it is essential that the refrigerant reaches a sufficiently high temperature when compressed, similarly, the fluid must reach a sufficiently low temperature when allowed to expand, in particular, the pressure difference must be great enough for the fluid to condense at the hot side and still evaporate in the lower pressure region at the cold side. The greater the temperature difference, the greater the required pressure difference, and consequently more energy is needed to compress the fluid. Thus as with all heat pumps, the energy efficiency (amount of heat moved per unit of input work required) decreases with increasing temperature difference.

Heat pumps are also available in reversible versions; this means that during winter season they produce heating, during summer period they can produce cooling.

This process is carried out by the use of a 4 way reversing valve; This valve switches between "heating mode" and "cooling mode" by an electric signal given via the unit controls. By switching the valve, the Freon flows one way to produce hot water and changes over via the control signal to produce chilled water.

THE SOURCE

The external medium from which the energy is absorbed is called cold source. In the heat pump the refrigerant fluid absorbs heat from the cold source in the evaporator. The LZT heat pumps use the ambient air as cold source, that's why they are identified as Air-to-water heat pumps.

THE USER

The air or the water to be heated is called hot user. In the heat pump the hot user is the condenser in which the refrigerant fluid transfers (releases) the thermal energy absorbed from the cold source. The thermal energy can be transferred to the building by:

- Fan coils,
- Radiators;
- Under floor heating.

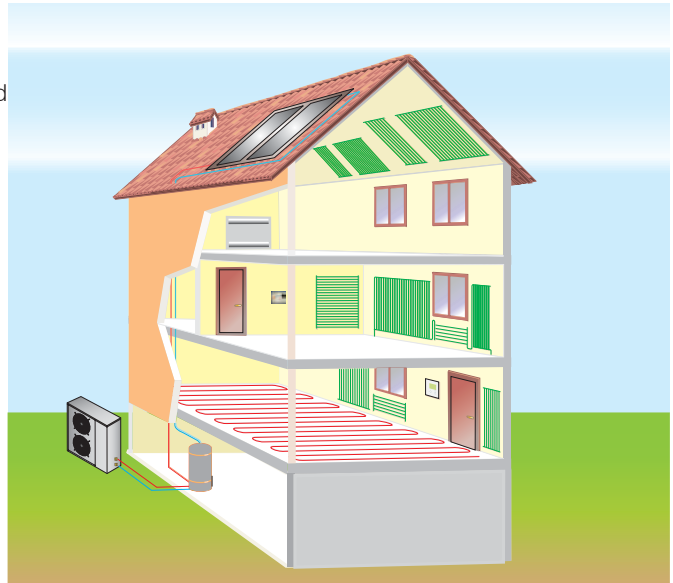

There are different types of heat pumps, classified by the type of cold source used; the main types are:

- **THE AIR TO WATER HEAT PUMPS;** where air is used as the cold source; it has the advantage of being available at all times; If air is used, as the cold source, it is necessary (around 0°C), to incorporate a defrost system into the source heat exchanger.
- **WATER TO WATER HEAT PUMPS;** where water is used as cold source; it grants the best performances without the variations of the external climatic conditions; furthermore the water is not always available, and it requires an additional cost due to the external hydraulic connections.
- **THE GROUND SOURCE HEAT PUMPS;** where, the cold source is used from the energy stored in the ground. The thermal energy (cold source) is ABSORBED from the ground by pipes that can be fitted either vertically or horizontally, designed to absorb the maximum energy possible.
The horizontal pipes are normally buried at 1 or 1,5 meters depth to avoid variations in the performances due to different ambient conditions and to keep the advantages of the solar irradiation. It is normally necessary for a pipe to have underground piping equating to 2-3 times more than the surface area of the area to be heated.

DEFROST CYCLE

The aspect that should be considered in the air to water heat pump is the occurrence of a problem with ice on the outdoor coil during cold ambient temperatures. As a fail-safe to this, the heat pump will melt this ice (defrost cycle) on its own, but it requires the switching of the valve to allow the Freon to run in reverse direction. After successfully melting the ice that builds up on the outside coils, the heat pump will then reverse the valve again and the refrigerant cycle. Inside coils are once again hot and outside coils are cold, and the heat pump will produce hot water again.

The defrost cycle absorbs energy from the heat pump, energy that is lost, and not put into the hot water circuit, temporarily reducing the heat pumps heating output. In most cases we can estimate that, in major European countries the energy lost during defrost cycle may vary from 5 to 13%.

EFFICIENCY OF THE HEAT PUMP

During its operation the heat pump:

- Absorbs Electric power in the compressor;
- Absorbs heat in the evaporator, from the surrounding environment (air or water);
- Releases the heat in the condenser (water).

The main advantage of the heat pump is the capacity to supply more energy (thermal) than the one required for its operation (electrical). The efficiency of a heat pump is measured by the coefficient of performance "C.O.P." is the **RATIO** between the thermal energy supplied at the hot user and the electric input power absorbed by the unit.

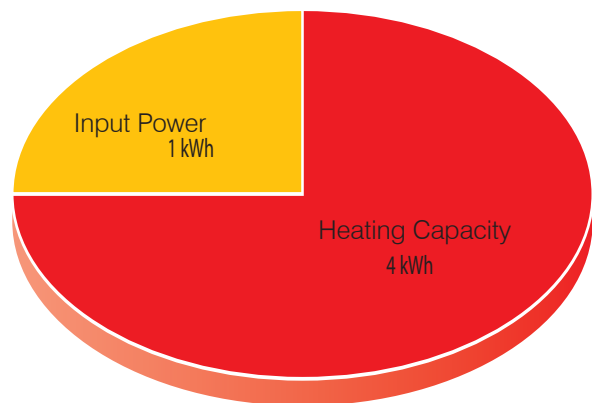

The C.O.P. is variable depending on the type of heat pump and the working conditions, and is generally around a value of 3 to 5. This means that for 1 kWh of electric input energy, the unit will supply 3 to 5 kWh of thermal energy to the hot user. The C.O.P. will vary, dependant on the temperature at which the heat is transferred, the colder the outdoor temperature the lower the C.O.P.

WHY USING A HEAT PUMP

The Graphic shows what is the use of energy in a typical North-European region (i.e. Germany):

- 77,8% Heating purposes;
- 10,5% Domestic hot water;
- 6,6% Domestic appliances;
- 3,7% Cooking;
- 1,4% Lighting.

It is evident how the reduction of the energy used for heating (is much more predominant compared to the other uses) allowing a massive reduction of the energy bill in different countries.

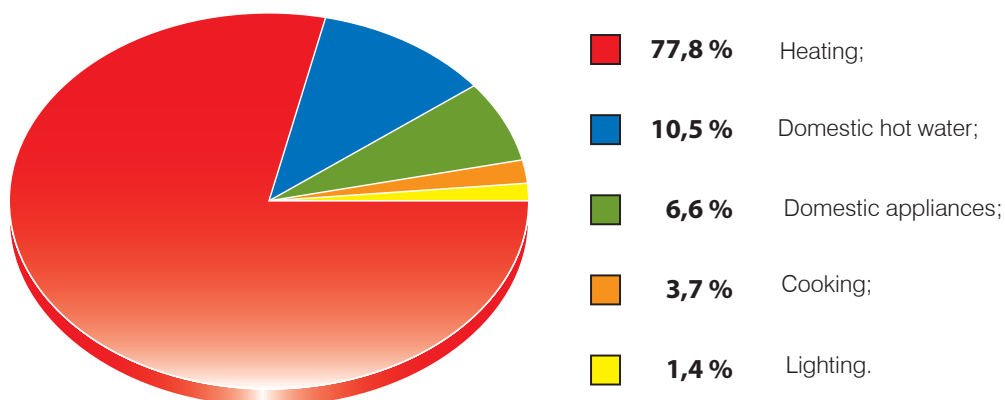

The heat pump by design is far more efficient than any other heat source available in the market. Where C.O.P.'s of between 3 and 5 have been generated, the energy used compared with a typical gas or oil systems is 3 to 5 times less. This means not only it gives running saving but also all other benefits which include:

- Low emissions of greenhouse gases like CO₂,
- Electricity is available everywhere so there is no limits on power supplies;
- Operation and use of renewable energy;
- Fuels are not necessary, or the use of gas /oil tanks for storage or gas lines into the building;
- No pollution on site;
- If the electricity used by the heat pump is produced by photovoltaic systems, we have an ideal system, with an environmental impact of ZERO.

THE USE OF PRIMARY ENERGY

The diagrams below show the use of primary energy by the different heating system available on the market.

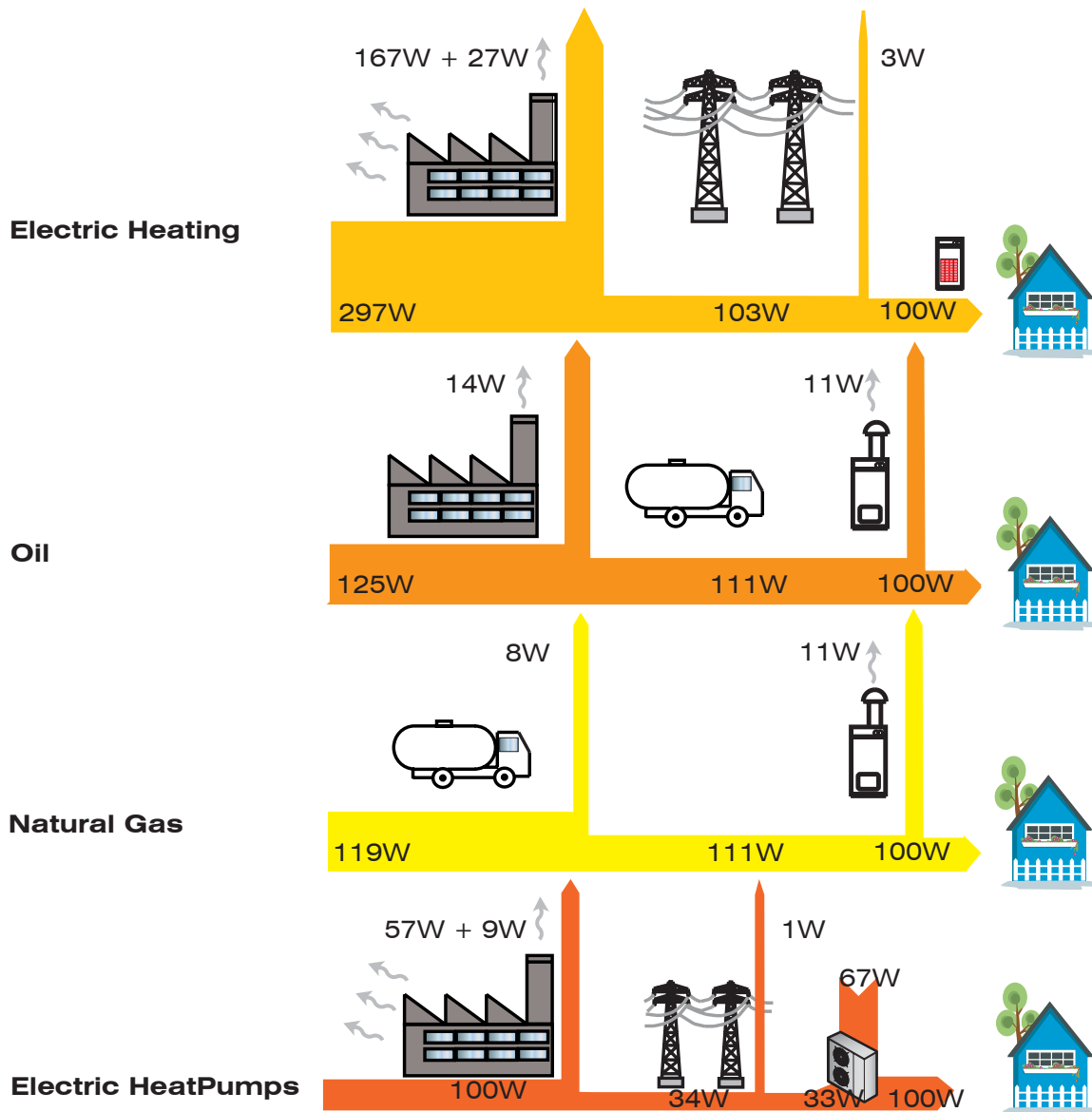

The use of heat pumps reduces to 100% the use of primary energy compared to other heating systems for example:

Electric heating (Primary energy used 297%),

Oil (Primary energy used 125%),

Natural Gas (Primary energy used 120%).

That means a massive reduction of CO₂ emissions!

HEAT PUMPS ARE THE HEATING SYSTEM OF THE FUTURE EASY TO MAINTAIN, EFFICIENT, ENVIRONMENT RESPECTFUL;

And more:

- The heat pump can be used for heating, cooling and domestic hot water production;
- Because of their efficient performance, many people have chosen to have heat pumps, simply for their excellent usage of energy. As a way of focusing on energy saving techniques, heat pumps go along way to keeping you warmer at a lower cost.
- The price of electricity remain quite stable; On the contrary gas prices today are almost double to those of 20 years ago.
- Once installed, the heat pump does not require maintenance.

COST OF NATURAL GAS (TO THE END USER) IN THE MAIN EUROPEAN MARKETS

Prices are net of national and local taxes, and are based on a domestic user with annual consume of 2.200 m3

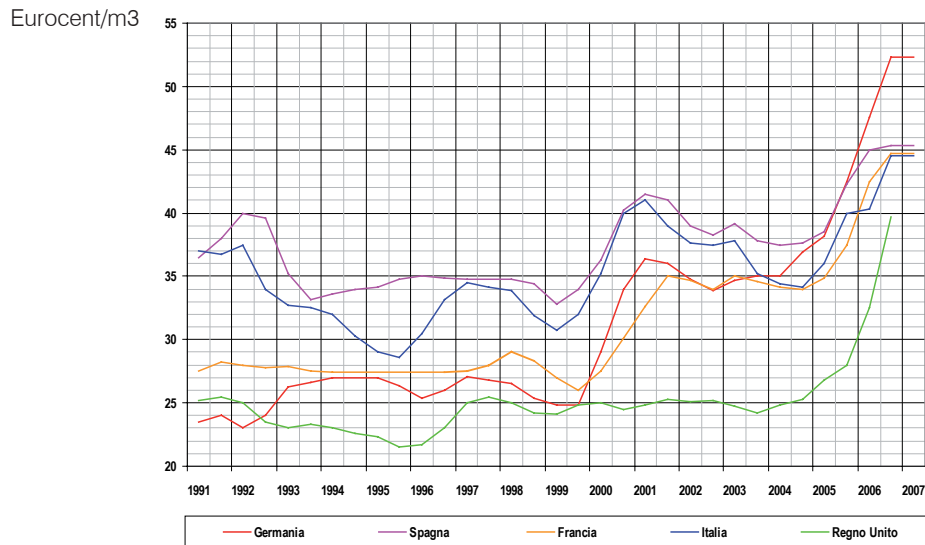

COST OF ELECTRICITY (TO THE END USER) IN THE MAIN EUROPEAN MARKETS

Prices are net of national and local taxes, and are based on a domestic user with annual consume of 3500 m3.

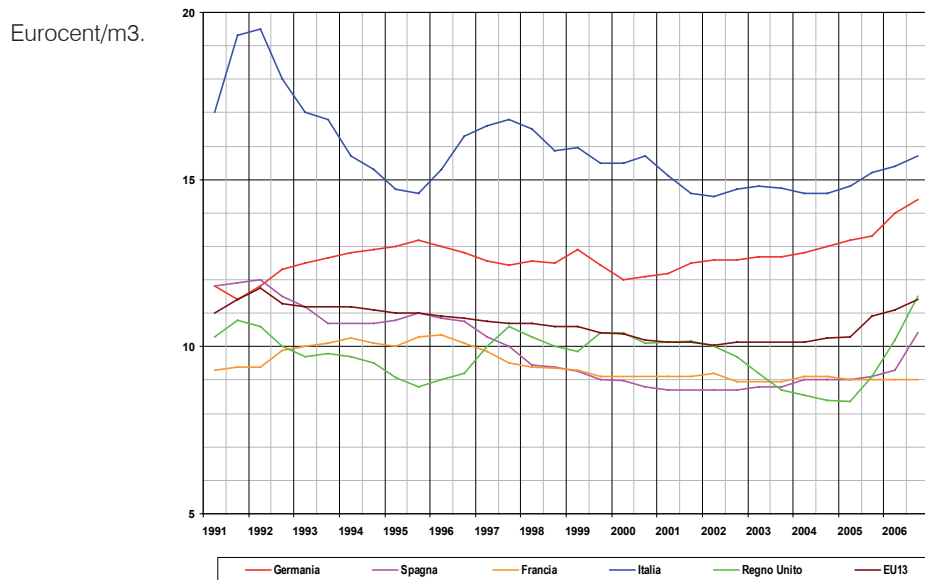

ECONOMICAL TREND OF ELECTRICITY AND OIL PRICE (BRENT DATED).

Index numbers : year 2000 = 100

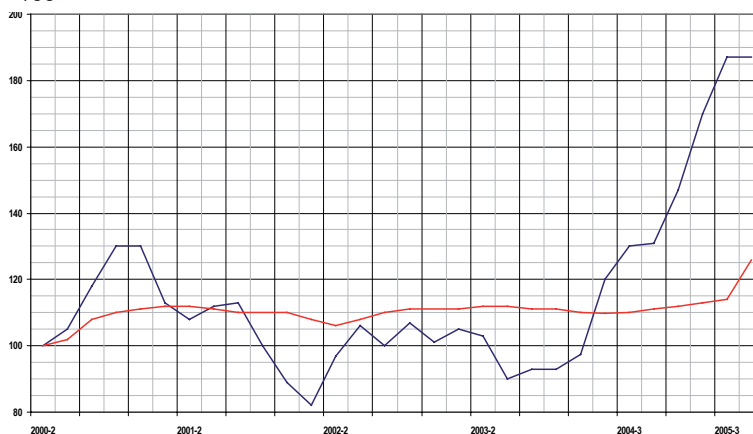

WHAT IS THE E.V.I. TECHNOLOGY (ENHANCED VAPOUR INJECTION)

HIDROS LZT heat pump units starting from model 10 are equipped with compressors supplied with E.V.I. technology, a versatile method of improving system capacity and efficiency. The vapour injection technology consists of injecting refrigerant vapour in the middle of the compression process, to boost capacities and efficiencies significantly. Each scroll compressor used in the LZT units is similar to a two-stage compressor but with built-in interstage cooling. The high stage consists of extracting a portion of the condenser liquid and expanding it through an expansion valve into a heat exchanger acting as a sub cooler.

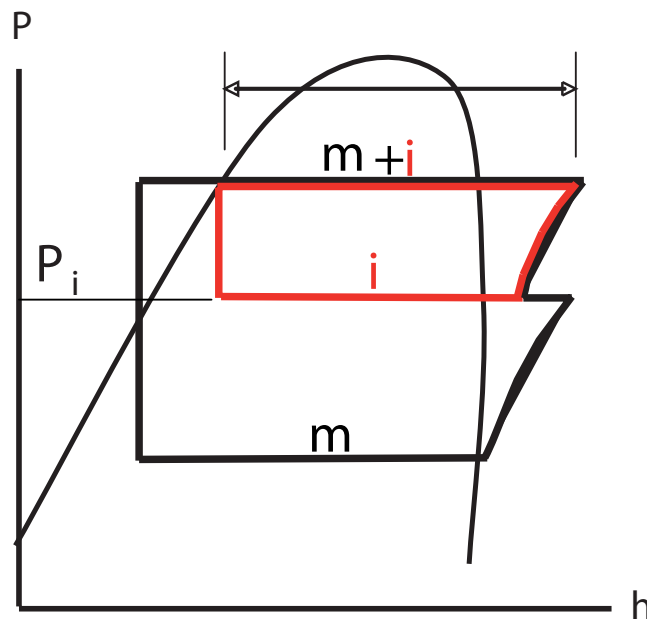

The superheated vapour is then injected into an intermediate port in the scroll compressor. The additional sub cooling increases the evaporator capacity. The bigger the pressure ratio between condensing and evaporating pressures, the more significant the performance gains with this system compared to any other compressor technology. This technology allows the LZT air to water HIDROS heat pumps to produce hot water up to 60°C with the possibility to operate down to -15°C ambient temperature.

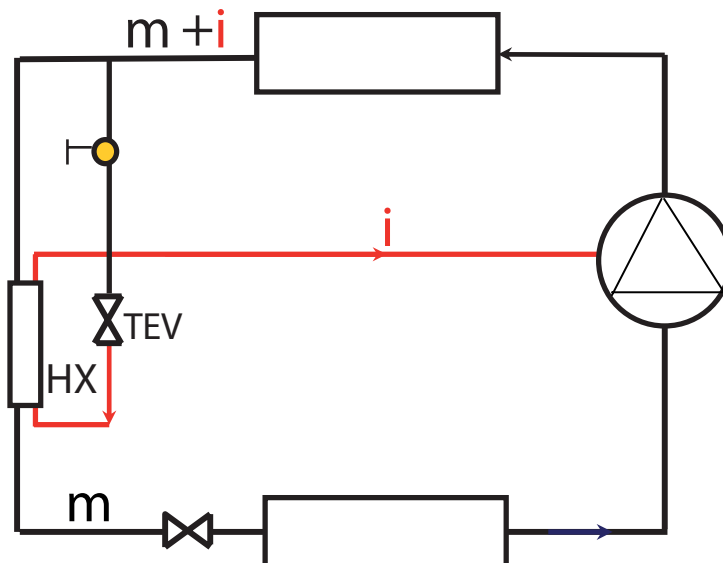

The graphics below show the trend of the coefficient of performance C.O.P comparing: Standard scroll compressor (Green curve); EVI scroll compressor (Blue curve).

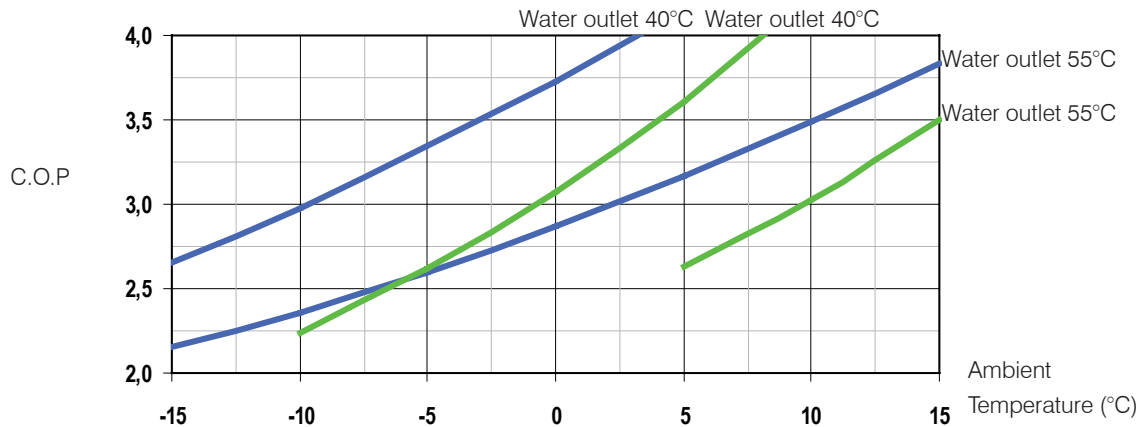

The efficiency of the EVI compressors at low ambient conditions is about 25% higher than the standard scroll compressors; Such differences become even much more evident in applications with quite high hot water temperatures (i.e. when domestic hot water is required), where we can also notice that the operational limits of a standard scroll compressor are not sufficient to produce the required hot water temperature at air ambient temperatures below 5°C. The above graphic shows the operation range of the EVI scroll compressors supplied in the HIDROS LZT units; at -15°C ambient the water outlet temperature is still 52°C; this allows the heat pump to be installed in much more diverse ambient conditions that are experienced in some countries.

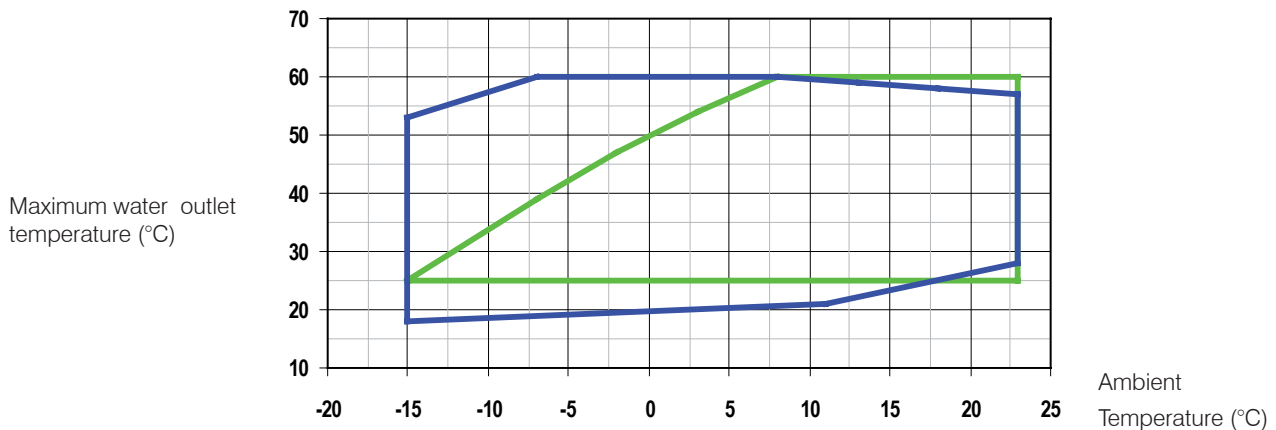

APPLICATIONS OF THE HEAT PUMPS

The application of the heat pump is by now commonly used both in residential, commercial buildings and in the service industry as an alternative to the ordinary systems of heating and cooling by boilers and water chillers. As a matter of fact the same unit is able to produce heating in winter and cooling in summer thanks to a simple valve, which changes the functions of evaporator and condenser (reversible type). The application of the heat pump for heating and cooling is much more efficient and the pay back is shorter time compared to a heating only application. The heat pump can be also used for the only production of residential heating and of the domestic water. For the residential heating the plants can be:

- Monovalent The Monovalent plant is used when the heat pump is able to satisfy the thermal loss necessary to heat the building.
- Bivalent The Bivalent system made up by the heat pump and by an auxiliary heating system, which can be a traditional boiler used to cover the thermal loss at very low ambient temperatures.

DOMESTIC HOT WATER (SW)

Hidros heat pumps are able to produce hot water up to 60°C, that allows the installation of the units in all applications in which also DOMESTIC HOT WATER (SW) is required. For the domestic water heating, there is the need of tanks bigger than those used in the normal boiler since the water temperature stocked doesn't normally exceed 45-50°C. The average domestic hot water use at 45°C is reported in the following table:

N°User	SW (lt/24h)	N°User	SW (lt/24h)	N°User	SW (lt/24h)	N°User	SW (lt/24h)
1	70	2	140	3	190	5	270

TYPICAL INSTALLATIONS

Type 1 Combined Heating / Cooling / Domestic hot water production – 2 PIPE SYSTEMS.

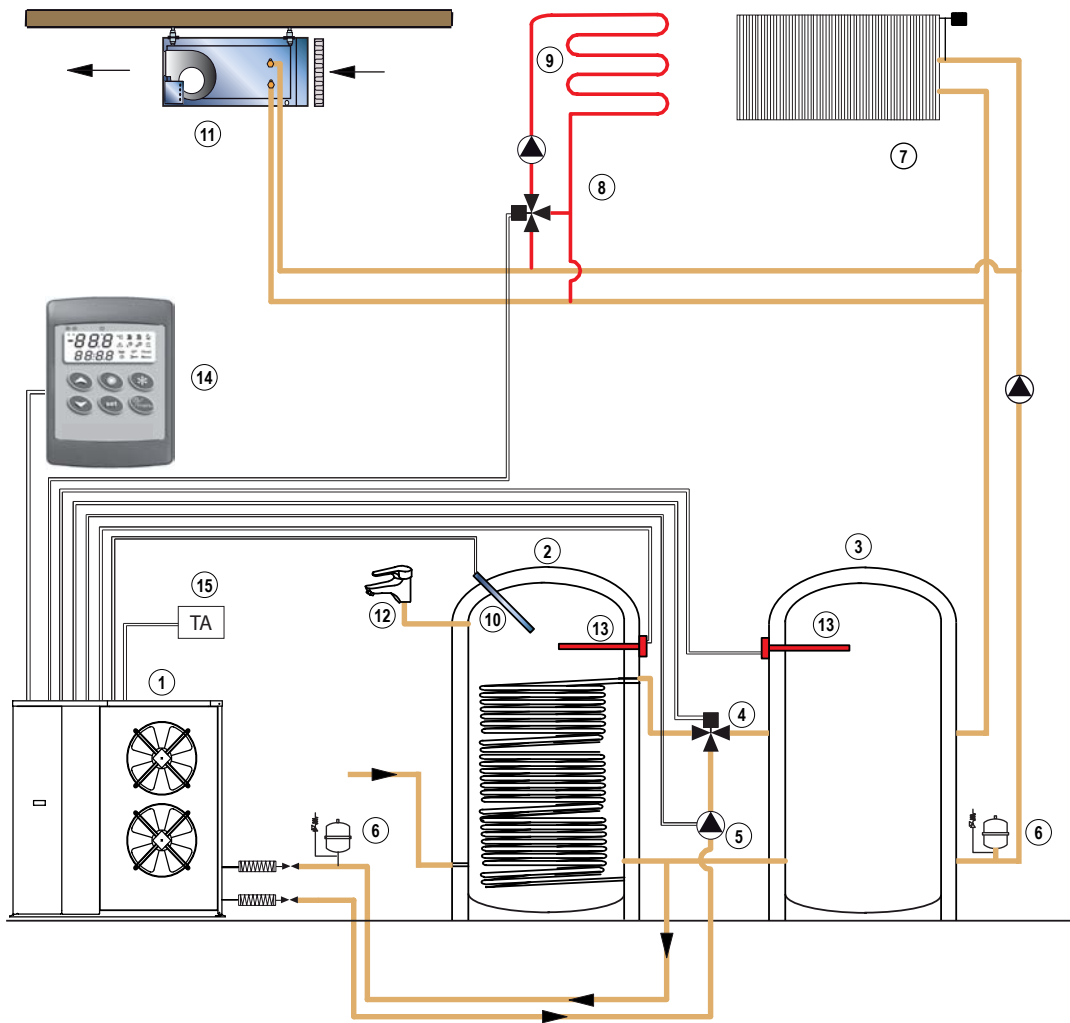

- | | |
|--------------------------------|---|
| 1 LZT Heat pump | 2 DHW Domestic hot water cylinder |
| 3 Buffer storage tank | 4 3 way valve Heating-Domestic hot water production |
| 5 Primary circuit water pump | 6 Expansion vessel |
| 7 Radiators | 8 Floor heating modulating valve |
| 9 Floor heating | 10 Domestic hot water sensor |
| 11 Dehumidifier/Cooling | 12 Domestic hot water |
| 13 Integration electric heater | 14 Remote control panel |

Such system combines heating at low temperatures, under floor heating and medium temperature water, radiators system. The DHW cylinder always produces domestic hot water with accumulation. The hot water produced by the heat pump is driven to the floor heating (at low temperatures e.g. 40°C) or to the radiators at higher temperature (e.g. 50°C). Such systems are extremely interesting in building renovations where it is not possible to remove completely the existing radiator heating system and where it is necessary to integrate with a higher performance under floor system in cooling mode (if available). The domestic hot water production has always the priority; it is activated by the domestic hot water sensor (10) which switches the position of the 3 way valve (4). In cooling mode, the system can also produce cold water for air conditioning (by switching the reversible valve installed standard in all LZT units) and, in case of necessity of domestic hot water, stops the production of cold water, switches the reversible valve in heating mode and the position of the 3 way valve (4), fills up the DHW cylinder (2) and, when the temperature measured by the DHW sensor (10) is the set one, it restores the normal operation in cooling mode.

TYPICAL INSTALLATIONS

Type 2 Combined Heating / Cooling / Domestic hot water production – 4 PIPE SYSTEMS.

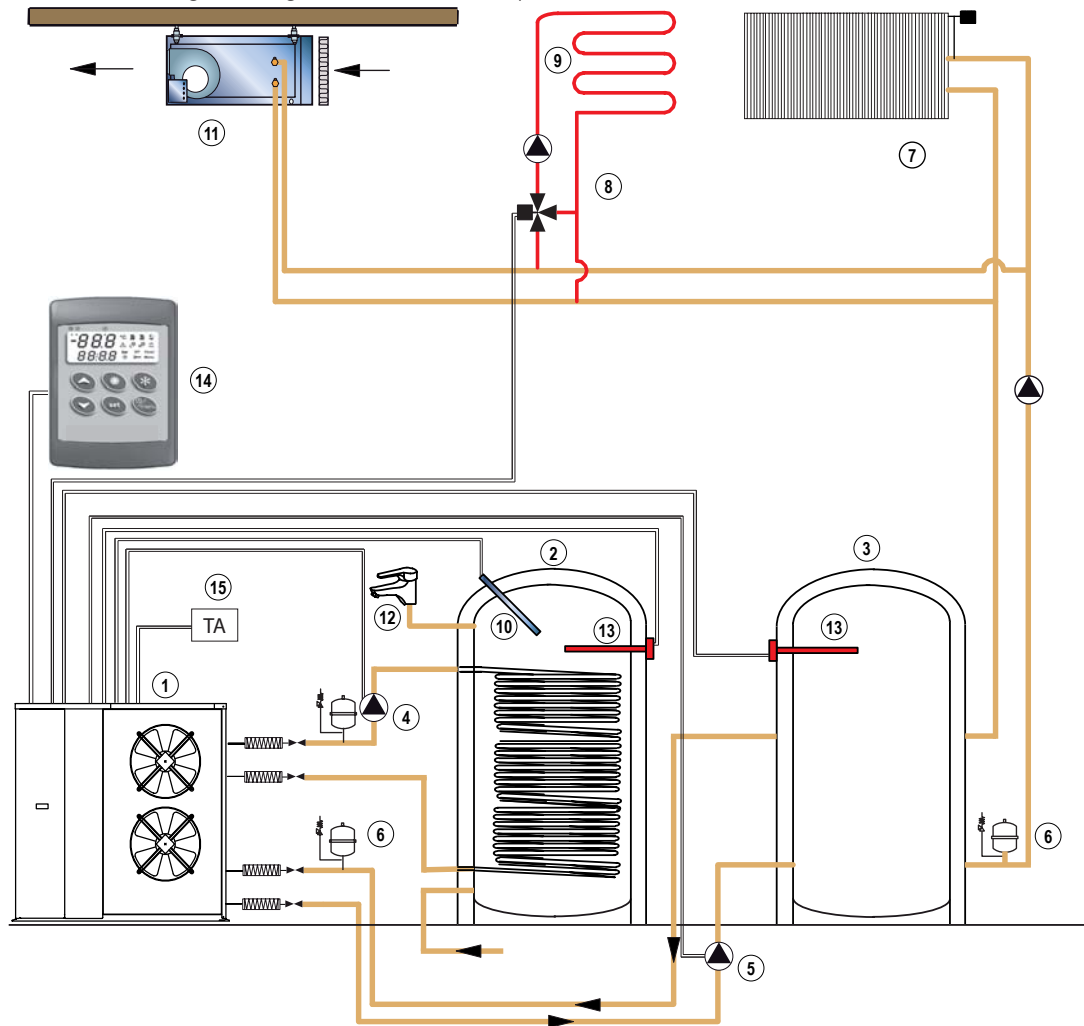

- | | |
|--------------------------------|-----------------------------------|
| 1 LZT/SW6 Heat pump(4 pipe) | 2 DHW Domestic hot water cylinder |
| 3 Buffer storage tank | 4 DHW water pump |
| 5 Primary circuit water pump | 6 Expansion vessel |
| 7 Radiators | 8 Floor heating modulating valve |
| 9 Floor heating | 10 DHW sensor |
| 11 Dehumidifier/Cooling | 12 Domestic hot water |
| 13 Integration electric heater | 14 Remote control panel |

This system allows the production of hot water for heating, domestic hot water and cold water by using a 4 pipe system. The LZT/SW6 has 4 water connections : 2 are connected to the domestic hot water circuit (DHW); 2 are connected to the heating/Cooling system. The hot water production has always the priority and its activation is made by the DHW sensor (10) which starts the domestic hot water pump (4)

In winter mode, the activation of the pump(4) stops temporarily the heating water that is normally restored when DHW cylinder has reached the set temperature (measured by the sensor 10).

In summer mode, the LZT/SW6 unit will switch into cooling mode (by activation of the reverse cycle valve installed in the unit) and, the eventual requirement of domestic hot water will allow, anyway, at the same time production of chilled water for airconditioning.

The system, in this operation mode, can produce cold water and domestic hot water at the same time. The domestic hot water, in summer mode, is produced through heat recovery and consequently, **FREE OF CHARGE**.

When the temperature measured by the sensor (10) is the set one, the pump (4) is stopped and it is restored the normal operation in cooling mode.

SEASONAL EFFICIENCIES

The Seasonal efficiency of the LZT heat pumps varies depending on the geographical location of the plant and the required temperatures in the building, here below are anyway reported the seasonal efficiencies of some LZT heat pumps applied to a building having the following data:

Heat loss of the building at -5°C : 5kW

End of the heating season: when the ambient temperature is above +15°C

Water temperature: 35/40°C

Room temperature: 20°C

Selected heat pump size: LZT 10T (400/3/50).

LOCALTION	Seasonal building Heat loss (kwh)	Seasonal LZT 10T Heating capacity (kwh)	Lost defrost energy (kwh)	Seasonal C.O.P
Milan	15831,00	15733,00	1732,00	2,9
Rome	9739,00	9739,00	400,00	3,5
Paris	16100,00	16100,00	1338,00	3,2
Amsterdam	18113,00	18113,00	1590,00	3,1
Koln	17525,00	17525,00	1726,00	3,1
Munich	21600,00	21300,00	2775,00	2,8
Berlin	19400,00	19200,00	2270,00	2,9
Birmingham	19264,00	19264,00	19264,00	3,1
London	19264,00	19264,00	1825,00	3,1
Wien	18409,00	18150,00	2265,00	2,8

SOFTWARES

Hidros has developed appropriate softwares to calculate the seasonal efficiency of the different types of heat pump either in monovalent or bivalent application considering the correct cost of the electricity in different countries and the application of the heat pumps in different location in Europe.

HidROS		HidROS srl											
		Sede legale: via della Croce Rossa 32/2 35129 (Pd) Italy Sede operativa: via dell'Industria 5, 35020 Brugine (Pd) Italy VAT IT 03598340283 Codice fiscale 03598340283 Tel. +39 049 9731022 Fax. +39 049 5806928 Web: www.hidros.it E-mail: info@hidros.it											
AIR-TO-WATER HEAT PUMP - WINTER SEASON SIMULATION COST													
Location:	Bologna	Project:											
Building heat loss -5°C a	5 kW												
Outlet water temperature	40 °C												
Indoor temperature	20 °C												
Number of persons	30												
Heat pump type	LZT10T 400/3	Daily Domestic HW quantity per person	50 Litres										
Electricity cost x kwh	0,17 Euro	Domestic HW outlet temperature	50 °C										
Additional heating cost	0,17 Euro	Domestic HW inlet temperature	10 °C										
Ambient temp. (Dry bulb)	°C	-18	-10	-5	0	5	10	15	20	25	30	35	Total
Heating capacity heat. m	kwh	5,12	5,99	6,94	8,04	9,26	10,59	12,05
Compr. input p. heat. m.	kwh	2,00	2,10	2,21	2,34	2,48	2,63	2,78
C.O.P. Compr. heat. mode	kw/kwh	2,56	2,84	3,14	3,43	3,73	4,03	4,33
DHW mode water out. t.	°C	50	50	50	50	50	50	50
Heating capacity DHW m	kwh	5,39	6,09	6,95	7,96	9,11	10,39	11,80
Compr. input p. DHW m.	kwh	2,52	2,59	2,69	2,82	2,97	3,14	3,31
C.O.P. Compr. DHW m.	kw/kwh	2,13	2,6	2,8	3,1	3,4	3,6	3,9
Fans	kw	0,2	0,2	0,2	0,2	0,2	0,2	0,2
Other electric loads HP	kw	0,0	0,0	0,0	0,0	0,0	0,0	0,0
C.O.P	kw/kwh	2,22	2,47	2,72	2,98	3,25	3,52	3,79
Hours	h	2,0	46,0	126,0	741,0	1618,0	1191,0	1546,0	1775,0	1564,0	488,0	64,0	8760
Building heat loss	kw	7,0	6,0	5,0	4,0	3,0	2,0	1,0
Building heat loss	kwh	14,0	276,0	626,0	2964,0	4854,0	2382,0	1546,0	12661,0
Domestic hot water cap.	kw	2,9	2,9	2,9	2,9	2,9	2,9	2,9
Domestic hot water DHW	kwh	5,8	133,2	363,4	2154,1	4703,5	3462,2	4494,2	15316,9
Building heat loss+DHW	kw	9,9	8,9	7,9	6,9	5,9	4,9	3,9
Building heat loss+DHW	kwh	19,8	409,7	988,4	5118,1	9557,5	5844,2	6040,2	27977,9
% Operation HP DHW	%	54%	48%	42%	37%	32%	28%	25%
Defrost energy lost	kWh	2,7	67,8	200,5	891,8	1184,9	0,0	0,0	2347,8
Defrost energy lost	%	27%	25%	23%	17%	12%	0%	0%	8,5%
HP seasonal work period	h	2	46	125	741	1178	592	502	3146,1
HP seasonal working per	%	100%	100%	100%	100%	73%	46%	32%
HP seasonal heating per	kWh	7,5	206,4	666,5	4917,6	957,5	5844,2	6040,2	27239,9
HP seasonal input energy	kwh	5,0	116,5	326,6	2012,8	3344,4	1639,3	1560,9	9005,4
HP electricity cost	€	0,8	19,8	55,5	342,2	568,6	278,7	265,3	1530,9
Additional electric heater	kw	6,1	4,4	2,6	0,3	0,0	0,0	0,0
Additional electric heater	kwh	12	20,3	322	200	0	0	0	737,9
Add. electric heating cost	€	2,1	34,6	54,7	34,1	0,0	0,0	0,0	125,4
Total electricity cost	€	2,9	54,4	110,2	376,2	568,6	278,7	265,3	1656,4
Seasonal efficiency of the heat pump													3,02
Seasonal efficiency of the heat pump + additional heating													2,80

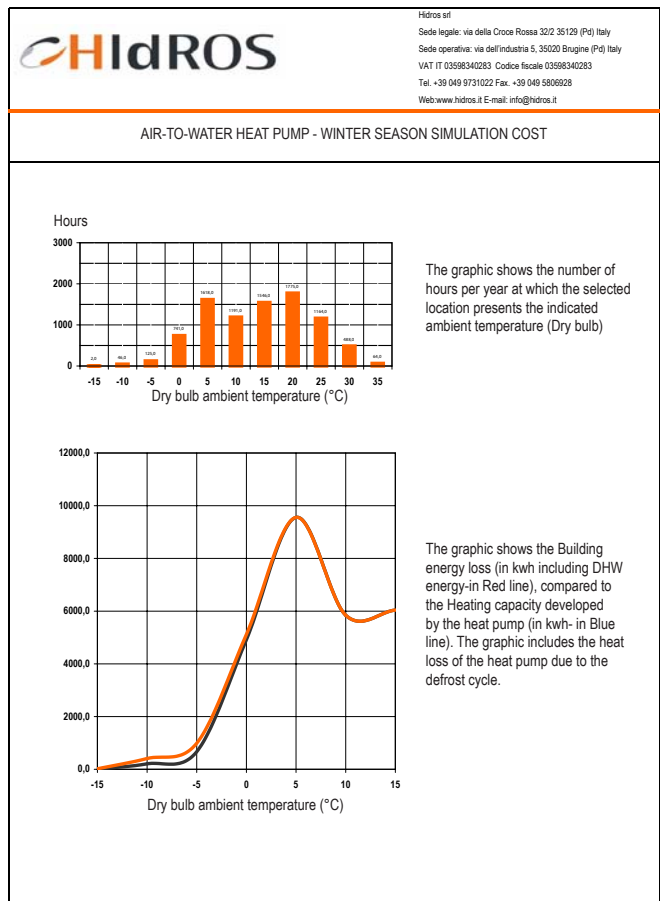

TECHNICAL CHARACTERISTICS

The high efficiency LZT heat pump series have been especially designed for application with radiant floor heating systems or in those applications where it is necessary to have the highest maximum efficiency in heating mode. The units have been optimized for heating mode, they are able to produce water up to 60°C and they can operate down to -15°C ambient temperature. All models are supplied standard with reverse cycle valve for cold water production. All LZT units are made from hot-galvanised thick sheet metal, painted with polyurethane powder, all screws and rivets for outdoor installations are in stainless steel.

The colour of the units is RAL 9018.

The refrigerant gas used in these units is R407C.



The compressors used are high performance scroll type, supplied with a special scroll design who enhance the efficiency of the refrigerant cycle at low ambient conditions. Units starting from model 10T are also supplied with economizer and EVI vapour injection system, a versatile method of improving system capacity and efficiency. The compressors are mounted in a separate chamber in order to be separated from the air stream.

The source heat exchangers are made of copper pipes and aluminium fins. The geometry of these heat exchangers guarantees a low air side pressure drop and then the use of low rotation (and low noise emission) fans.

The fans are axial type with aluminium aerofoil blades.

The user heat exchangers are made of AISI 316 stainless steel braze-welded plates type.

The electric box is made according to electromagnetic compatibility norms CEE 73/23 and 89/336.

All LZT units are supplied standard with microprocessor control, they are also supplied with water sensors, high and low pressure switches, safety valve, compressor thermal overload protection, fans thermal overload protection, pressure transducer (used to optimize the defrost cycle and the fan speed depending on the ambient conditions), flow switch.

OTHER VERSIONS

LZT/SW6 UNIT WITH DOMESTIC HOT WATER PRODUCTION

This version is suitable to produce domestic hot water: the unit is supplied with an additional heat exchanger used as condenser for the domestic hot water that, is independently from the operation mode of the unit. The activation of the additional heat exchanger is done automatically by the microprocessor control when the domestic hot water temperature measured by the sensor is lower than the required set point. This unit allows the production of cold and hot water at the same time independently. This version is supplied with return/supplied domestic hot water sensors and advanced control panel with specific software able to manage the operation priorities.

LZT / A1 HIGH EFFICIENCY HEAT PUMP WITH INTEGRATED HYDRAULIC KIT

The LZT heat pumps can be delivered as option, with a built in hydraulic kit that includes:

Water tank in different sizes (depending on the size of the unit), factory insulated with flexible close cell material and prepared for the installation of antifreeze kit (option). The water tank is installed on the hot water outlet water side to minimize the inevitable fluctuations in the water temperature due to the compressors starts and stops.

Water pump, centrifugal type, suitable for chilled water operation. The pump is directly controlled by the microprocessor that controls its correct operation. In the hydraulic circuit are also present the expansion vessel, the safety valve and the eventual manual valves with fittings.

LZT/LS LOW NOISE VERSION

This version includes the complete acoustic insulation of the unit (compressor + heat exchangers vanes) with compressor jackets and insulating material made with high density media and the interposition of heavy bitumen layer.

MOD.		06	08	10M	10T	14M	14T	21
Refrigerant		R407C	R407C	R407C	R407C	R407C	R407C	R407C
Heating capacity ⁽¹⁾	kW	6,4	8,7	9,4	9,9	13,9	14,6	20,9
Heating capacity ⁽²⁾	kW	6	8,2	9,4	9,8	14,2	14,6	20,3
Heating capacity ⁽³⁾	kW	5,3	7,2	8,4	8,7	12,8	13,2	18,4
Total input power (EN14511) ⁽¹⁾	kW	1,6	2,2	2,5	2,6	3,6	3,5	5,2
C.O.P (EN14511) ⁽¹⁾	W/W	3,9	4	3,8	3,9	3,8	4,1	4
Domestic hot water capacity ⁽⁴⁾	kW	5,1	6,8	8,1	8,5	12,5	12,9	18
Total input power (EN14511) ⁽⁴⁾	kW	2,1	2,7	3	3,1	4,6	4,5	6,4
Cooling capacity ⁽⁵⁾	kW	8,1	9,8	11,9	12,2	16,9	16,5	25,1
Total input power (EN14511) ⁽⁵⁾	kW	2,4	2,9	3,5	3,6	4,7	4,6	6,8
E.E.R (EN14511) ⁽⁵⁾	W/W	3,4	3,4	3,3	3,3	3,6	3,9	3,7
Power supply	V/Ph/Hz	230/1/50			400/3+N/50	230/1/50	400/3+N/50	
Fans	n°	1	1	1	1	2	2	2
Compressor	type	Scroll		Scroll with economizer and vapour injection				
	n°	1	1	1	1	1	1	1
Refrigerant circuit	n°	1	1	1	1	1	1	1
Sound power level ⁽⁶⁾	dB(A)	68	68	68	68	70	70	74
Sound pressure level ⁽⁷⁾	dB(A)	40	40	40	40	42	42	46
Water pump (optional)	kW	0,13	0,13	0,2	0,2	0,3	0,3	0,45
Water tank capacity (optional)	lt.	40	40	40	40	60	60	60

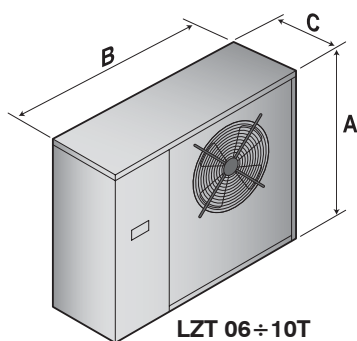

Mod.	A (mm)	B (mm)	C (mm)	Kg
06/06A1	989	1103	380	95/148
08/08A1	989	1103	380	104/163
10M/10MA1	989	1103	380	118/179
10T/10TA1	989	1103	380	120/181

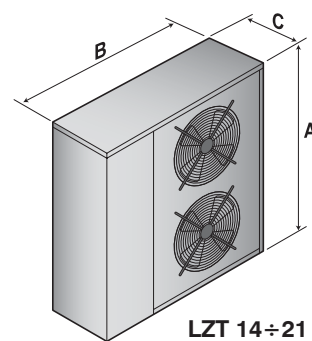

Mod.	A (mm)	B (mm)	C (mm)	Kg
14M/14MA1	1323	1203	423	127/207
14T/14TA1	1323	1203	423	133/212
21/21A1	1424	1453	473	390/550

Performances are referred to the following conditions:

⁽¹⁾ Heating: Ambient temperature 7/6°C; Water 35/30°C.

⁽²⁾ Heating: Ambient temperatura 2/1°C; Water 50/45°C.

⁽³⁾ Cooling Ambient temperature 35°C; Water 23/18°C.

⁽⁷⁾ Sound pressure level measured at 10 mt from the unit in free field conditions direction factor Q=2 according to ISO 3746.

⁽²⁾ Heating: Ambient temperature 7/6°C; Water 50/45°C.

⁽⁴⁾ Domestic hot water capacity: Ambient temperature 2/1°C; Water 50/45°C.

⁽⁶⁾ Sound power level according to ISO 3746.

MOD.		26	36	46	52	72	82	92
Refrigerant		R407C	R407C	R407C	R407C	R407C	R407C	R407C
Heating capacity ⁽¹⁾	kW	26,2	36,6	43,7	54,8	73,3	87,6	104,2
Heating capacity ⁽²⁾	kW	26,8	35,9	44,8	56	71,8	89,9	104,6
Heating capacity ⁽³⁾	kW	24	32,2	40,5	50,1	64,4	81,2	93
Total input power (EN14511) ⁽¹⁾	kW	6,4	8,6	10,1	13,6	17,8	20,9	25,5
C.O.P (EN14511) ⁽¹⁾	W/W	4,1	4,3	4,3	4	4,1	4,2	4,1
Domestic hot water capacity ⁽⁴⁾	kW	23,4	31,1	39,4	45,6	62,2	78,8	90,9
Total input power (EN14511) ⁽⁴⁾	kW	8,1	11,1	13	17,6	22,1	26,7	30,9
Cooling capacity ⁽⁵⁾	kW	29,1	45,1	50,3	61,9	85,0	98,0	126,5
Total input power (EN14511) ⁽⁵⁾	kW	8,1	12,2	11,8	17,2	24,3	26,5	33,3
E.E.R (EN14511) ⁽⁵⁾	W/W	3,9	4,3	3,4	3,7	4,1	3,9	4
Power supply	V/Ph/Hz	400/3+N/50			400/3/50			
Fans	n°	2	2	2	2	2	2	3
Compressor	type	Scroll with economizer and vapour injection E.V.I						
	n°	1	1	1	2	2	2	2
Refrigerant circuit	n°	1	1	1	1	1	1	1
Sound power level ⁽⁶⁾	dB(A)	79	79	79	82	82	82	83
Sound pressure level ⁽⁷⁾	dB(A)	51	51	51	54	54	54	55
Water pump (optional)	kW	0,55	0,55	0,99	1,3	1,3	1,5	1,5
Water tank capacity (optional)	lt.	180	180	300	300	300	300	300

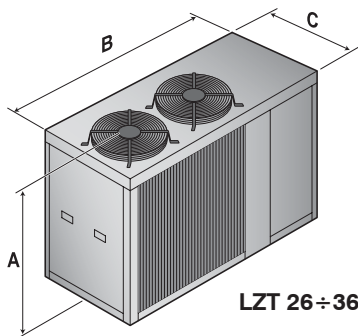

LZT 26÷36

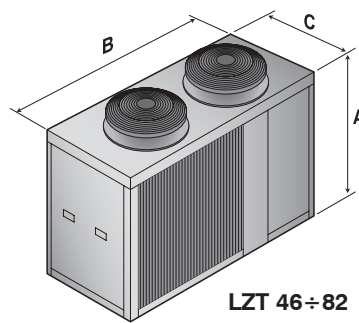

LZT 46÷82

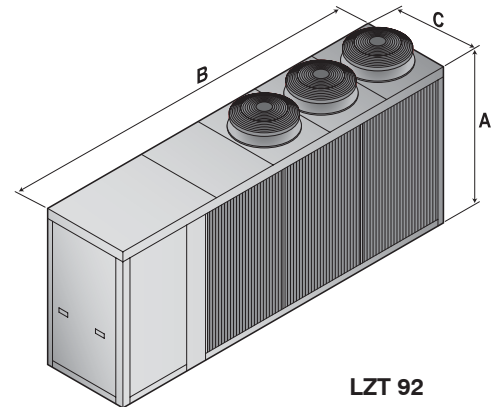

LZT 92

Mod.	A (mm)	B (mm)	C (mm)	Kg
26/26A1	1406	1870	850	350/510
36/36A1	1406	1870	850	390/550
46/46A1	1759	2608	1105	660/810

Mod.	A (mm)	B (mm)	C (mm)	Kg
52/52A1	1759	2608	1105	710/880
72/72A1	1842	2608	1105	725/895
82/82A1	1842	2608	1105	810/980
92/92A1	1842	3608	1105	1070/1280

Performances are referred to the following conditions:

⁽¹⁾ Heating: Ambient temperature 7/6°C; Water 35/30°C.

⁽²⁾ Heating: Ambient temperatura 2/1°C; Water 50/45°C.

⁽³⁾ Cooling Ambient temperature 35°C; Water 23/18°C.

⁽⁷⁾ Sound pressure level measured at 10 mt from the unit in free field conditions direction factor Q=2 according to ISO 3746.

⁽²⁾ Heating: Ambient temperature 7/6°C; Water 50/45°C.

⁽⁴⁾ Domestic hot water capacity: Ambient temperature 2/1°C; Water 50/45°C.

⁽⁶⁾ Sound power level according to ISO 3746.



Hidros srl
Via dell'Industria 5
35020 Brugine (PD)
Tel +39 049 9731022
Fax +39 049 5806928
www.hidros.it
e-mail: info@hidros.it