

DESIGN GUIDE

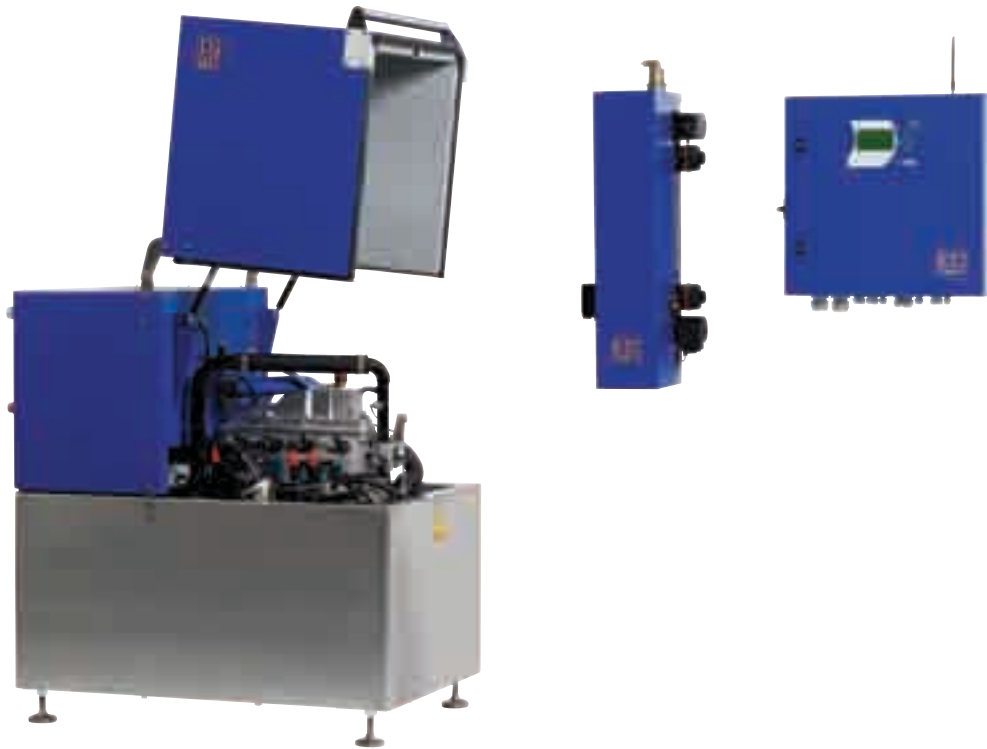

XRGI Combined Heat and Power System

Please check with EC Power UK Ltd before final design

Requirements to the heating system

MODES OF OPERATION

EC Power CHP hydraulics

The hydraulics in the EC Power CHP system is based on intensive research and many years of experience in CHP/District Heating in Denmark, and it can be described as a “Micro district heating system”. Correct functioning of the CHP system depends on a few general design requirements in the heating system.

Heating system with storage capacity

The EC Power CHP system must have a storage capacity for excess heat, as a CHP unit is based on an engine that cannot start and stop in the same frequency as a gas or oil boiler.

Optimal Power Mode (Normal operation)

In this mode of operation the system will schedule power production to times when it is of highest value to the site (at highest cost). If a low heat demand occurs during this period then the heat storage is filled so that the heat can be used at a later time. For this reason it is necessary to use a minimum of 500 litres of storage however a greater storage capacity will enable longer running.

Site electric demand is monitored by the system and the system changes output to try to match demand (within 0.5 seconds). Where site demand is higher than the maximum output from the system extra electricity is then imported from the grid supply.

Heat demand Mode

If the site electric demand is always greater than the maximum power output from the system or if a sales export tariff has been arranged you may opt to have the unit in heat demand mode. In this mode the unit will respond to the heat demands of the site with no regard to the sites power consumption, thus always producing the maximum electricity and heat.

The EC Power CHP unit can be connected to a larger storage tank, or more storage tanks in series, when there is room for this at the installation site, and it is required from peak loads in the heating system. The storage must be connected as instructed in this guide.

When the heat consumption is subject to large variations over a daily period, it is of utmost importance that the storage capacity is adequately dimensioned. In this way the EC Power CHP unit can supply even large peaks in the heat consumption, thus securing maximum running hours.

In a large number of installations, with the main source of heat consumption during the summertime being hot water production, the storage capacity is important in order for the CHP unit to be able to produce this hot water.

- In any heating system with storage, a constant difference between the flow and return temperatures must be maintained, as the storage capacity is greatly affected by the temperature of the circuit.

I.e. No ΔT = NO STORAGE

In certain heaters (hot water boilers and air heaters) it is necessary to install return temperature limiting valves, to keep the return temperature low. Preferably the low is min. 30 degrees below the flow temperature.

EC Power Stratification Storage

The storage tank in the EC Power CHP system is storing in two stratum: Hot (top) and cold (bottom) divided through a separating layer. It is possible to connect more storage tanks in series, to obtain a larger storage capacity.

The top of the storage tank is connected to the hot water outlet from the CHP unit and the flow water to the heating system, and the bottom of the tank is connected to the return water from the heating system and the return water inlet to the CHP unit.

When the EC Power CHP unit produces more heat than is consumed, the hot water is filled in the top of the storage tank. When more heat is consumed than there is produced, the hot water is then taken out from the top of the storage tank, in this way the flow direction in the tank is reversed.

This way of storing heat results in a very high usage of the storage capacity, as the storage tank can deliver cooling water for the CHP unit until it is totally filled with hot water, as well as deliver the full capacity as hot flow water.

Storage tanks with more than two connection points will not function as storage for the EC Power system, as the hot and the cold water will be mixing, and this is not supporting the way that the EC Power system monitors the progression of the stratification layer.

A “mixing storage” will also have a much lower usage of the capacity in the storage tank, as a lower part of a “full” tank will be really hot, as well as an “emptied” tank will not be all cold.

“Full storage” in a CHP system means that the cold return from the storage tank is not cold enough to cool the CHP, and “empty storage” means that the hot flow water from the storage tank is not adequately warm to be system flow water.

Correct: EC Power storage tank

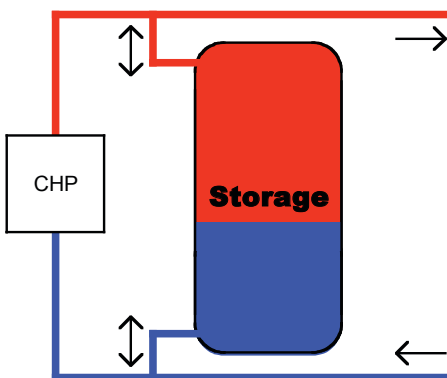

Incorrect: Mixing storage

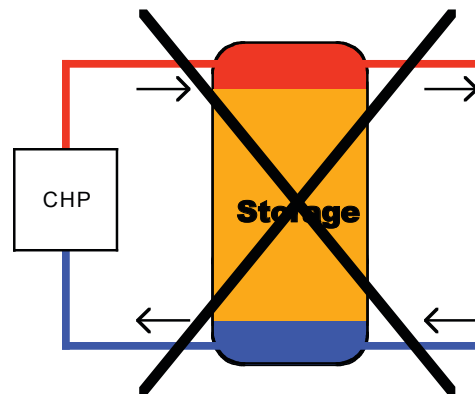

Heat Distributor - Function / Malfunction

The EC Power Heat Distributor is continuously monitoring the heat storage circuit and engine cooling circuit. The storage is monitored using four sensors in each storage tank, as well as sensors in the heat distributor. In this way the system knows the quantity of heat being stored.

When the storage is full, the return water temperature in the heat distributor will rise, and the CHP will stop until there is sufficient demand to reduce the return temperature and the quantity of stored heat.

Hot return water from the heating system to the CHP will also be registered as “storage full”, and will therefore stop the XRGi CHP.

Typical short circuits in a heating system

The hot water boiler is often responsible for high return temperature, especially at the end of the boiler running cycle. It is very important that the circulating pump for the hot water boiler is stopped, before the return temperature from the boiler rises up near the flow temperature.

When the hot water boiler cycle cannot be stopped in time with the existing control, a return temperature limiting valve can be built into the hot water boiler return pipe, to reduce the flow through the boiler according to the return water temperature.

The installation of heat loads can roughly be divided into the following hydraulic systems. In order to avoid an accidental short circuit of the hydraulic system, a temperature limiting valve has to be installed in the return line, when the heat load is regulated, by leading a part of the flow water directly to the return line. (Bypass and injection connections)

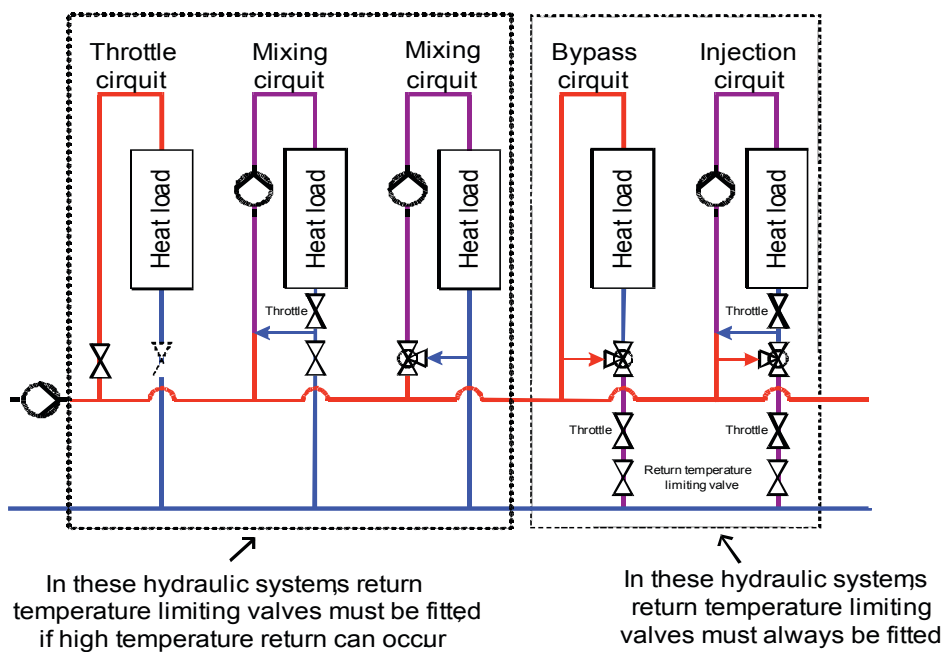

Typical short circuits in a heating system (continued)

Some boiler systems have a by-pass pipe connection between the flow and return header in order to maintain the boiler minimum flow. During low heat demand, this flow will cause the temperature in the return header to rise to an inappropriate level.

If the CHP is installed in the return header, the system by-pass pipe must be disconnected or closed. A by-pass connection close to the boiler is then to be installed, sized to maintain the minimum flow of the boiler.

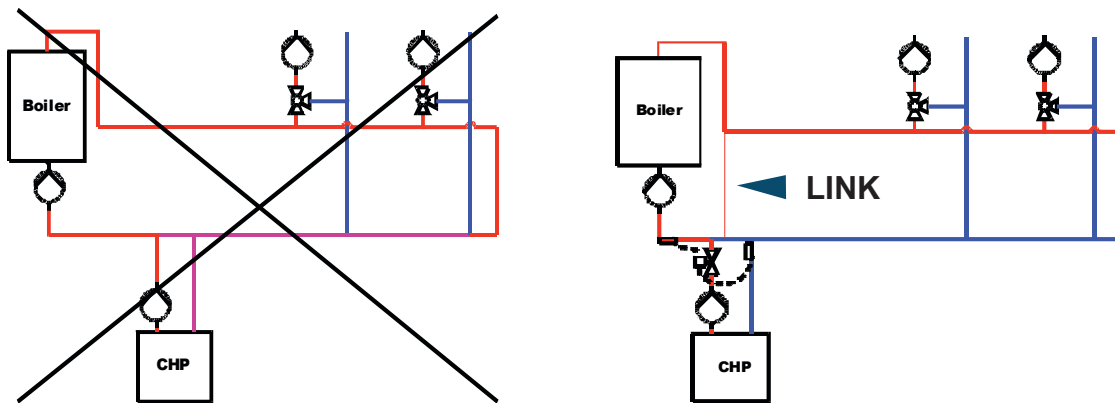

Summary

For all types of applications of the EC Power CHP system, it is very important that all connected heat loads are hydraulically balanced and thermostatically regulated, so that there can be no water flow through the circuit, without the water being adequately cooled down.

Water flow directly to the return without, or with only very little cooling, can be described as a short circuit, and it will result in malfunction of the CHP and the storage system.

With controlled cooling through all the heat loads, a high usage of the storage capacity is achieved, and thereby also the highest possible use of the CHP system.

By some types of heat loads, e.g. hot water boilers and air heaters, it may be necessary to install return temperature limiting valves, in order to secure a low return temperature.

Heating system diagrams

Serial connection with a small condensing boiler

The EC Power heat distributor will control the boiler and the storage system.

Fig. 1: Serial connection with a small condensing boiler. Maximum flow is 2.5m³/h, with flow temperature control.

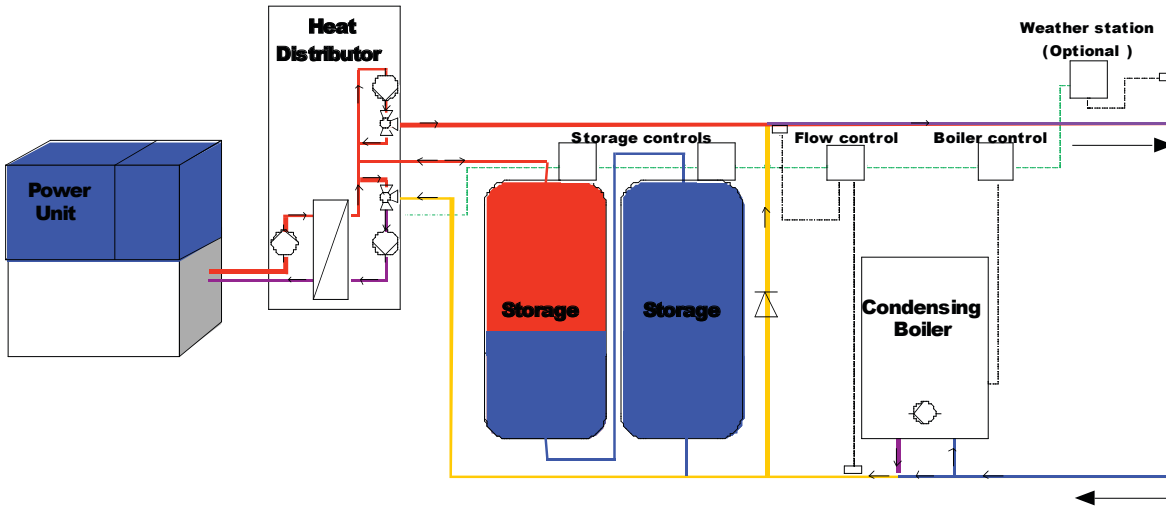

- A small condensing boiler can be connected in the return line.
- The Q-Network Boiler Control must be installed to control the boiler.

This hydraulic system can handle up to approx. 30 kW boiler capacities.

The boiler will not be running when there is heat stored in the storage.

When the storage is almost empty, and the boiler starts, the boiler will preheat the water to the CHP, and/or feed flow water directly through the mixing bypass, depending on boiler flow temperature (automatically regulated by the Flow Control).

If there should be a problem with the CHP system, the boiler can feed the system by itself through the bypass (CHP flow valve closes).

Parallel connection with boiler

The EC Power heat distributor will control the boiler and the storage system, Fig. 2.1 and Fig. 2.2 capable of a maximum flow of $2.5 \text{ m}^3/\text{h} + \text{Boiler Capacity}$.

Fig. 2.1: Boiler parallel to Heat Distributor, with flow temperature control.

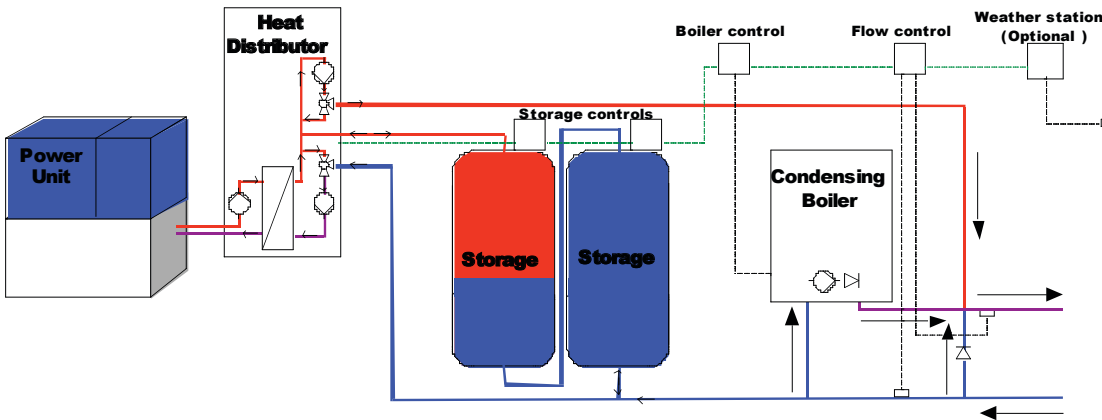

Fig. 2.2: Connection to low loss header, with flow temperature control.

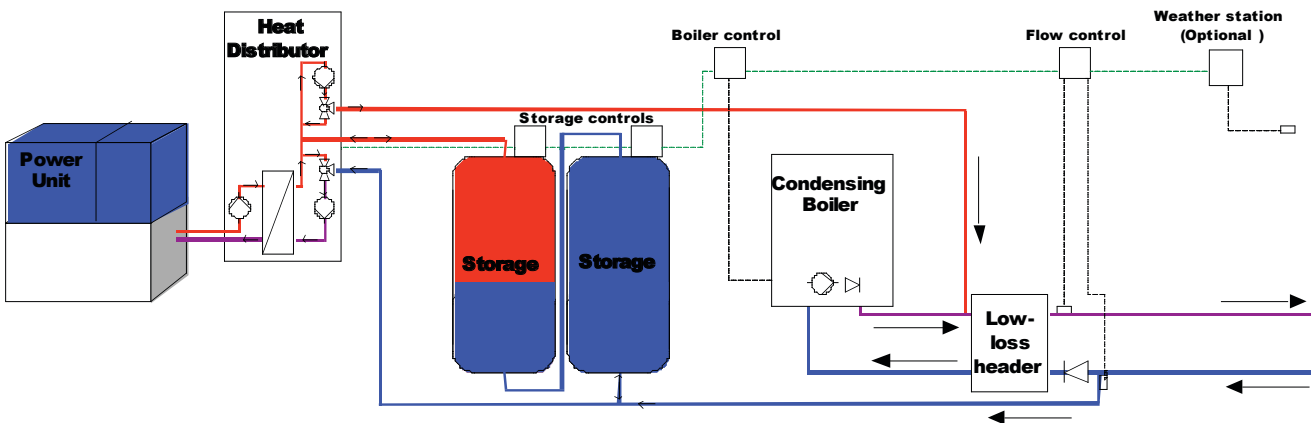
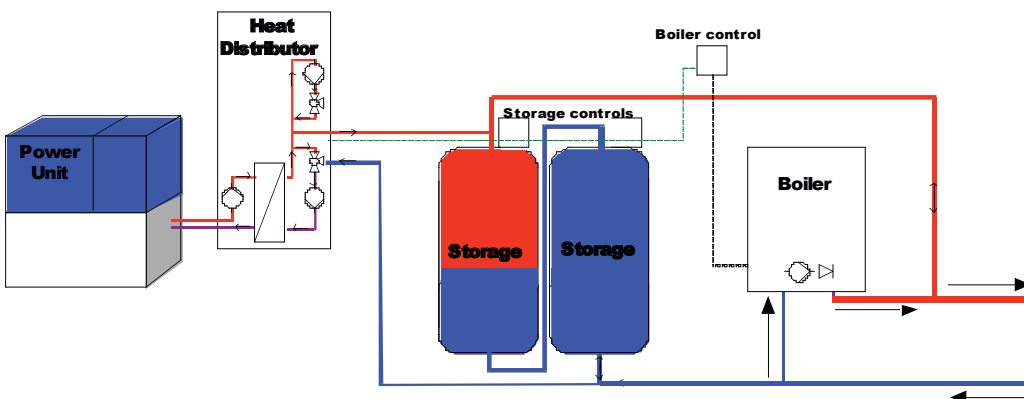

Fig. 2.3: Boiler parallel to storage. Boiler flow temperature min. 75°C . Maximum flow (Heat output) increases corresponding to pipe dimensions in the storage system. No flow temperature control. (Flow temp. min. 75°C)



When installing together with larger condensing boiler systems, the boiler should be connected parallel to the EC Power Heat Distributor. In this way of connecting, the boiler circulating pump must switch off, when the boiler is not running, and backwards circulation through the boiler must be blocked.

Boiler return pre heat increase

The EC Power heat distributor controls the storage loop and increases the return water temperature to the boiler. (Not suitable for condensing boilers)

Fig. 3: Serial connection with larger non-condensing boiler.

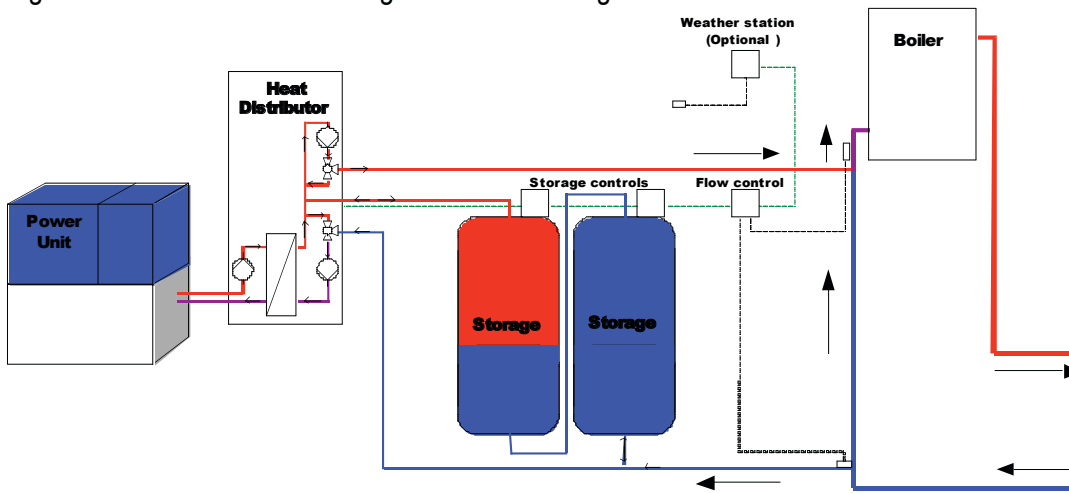

The system can be installed as boiler return water temperature pre-heat. In this way a portion of the boiler return water will be fed to the EC Power system.

From here the hot flow water from the EC Power system is fed back and mixed into the boiler return water.

The Q-Network Flow Control measures the temperature in the mixed boiler return water, and controls the CHP flow according to heat consumption.

The Flow control also measures the temperature in the return water to the CHP, and closes the flow valve, if hot water should return.

If the set point for the temperature in the boiler is controlled by ambient (outside) temperature, a Q-Network Weather Compensator must also be installed, to regulate the flow temperature from the CHP accordingly.

Electrical Requirements

The CHP system must be fused (gl/gG melting fuses) by either a 50 A (for gas systems) or a 63 A (for oil systems) at its supply.

Two modes of operation: The EC Power CHP Unit can operate in either optimal power mode or heat demand mode and can be set at time of commissioning.

In this mode the unit will measure the instantaneous site electrical demand and try to match this demand by modulating the electrical power produced. The unit will also “learn” the site’s electrical demand profile and optimize the operation to ensure that electricity is provided at periods of highest demand.

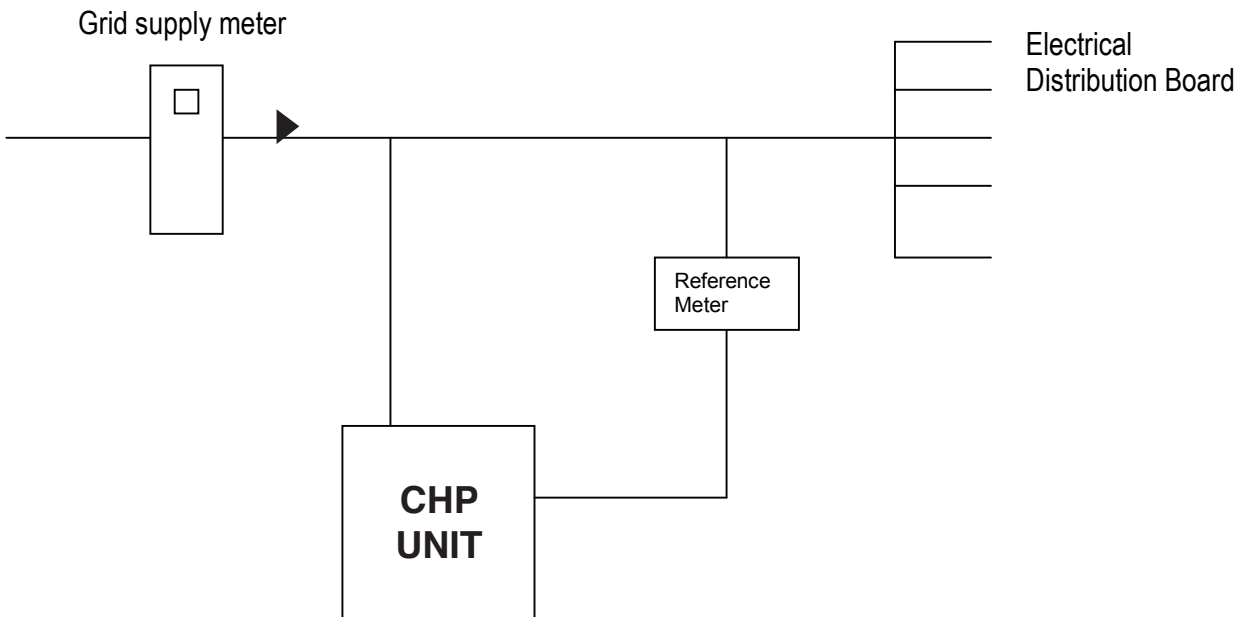

Electrical Export Mode

It is also possible to set the unit to a fixed electrical output, thus any electric power produced that is not used on site is then “exported”. The export function can be accessed from the Control Panel by the user.

Heat demand mode

In this mode the EC Power CHP Unit will operate to supply the site with heat as its priority. It will ignore site changing electrical loads and assure a minimum demand for electricity. In this mode of operation an electrical reference meter is not required.

Tables of cable dimensions:

Note! All cable lengths and dimensions are recommended by EC Power, as parallel routing, ambient temperature, mechanical and chemical effects, etc. must also be taken into account for every single installation.

Wire material	Recommended cable type	Numbers of wires x cross-section [mm ²]	Recommended max. length
<i>Installation cable supply/production (from supply point to control panel).</i>			
Cu		5 x 10	100 m.
Cu		5 x 16	150 m.
<i>Power/production cable (from control panel to power unit).</i>			
Cu		4 x 10	10 m.
<i>Control cable (from control panel to power unit).</i>			
Cu		12 x 0,75	15 m.
Cu		2 x (4 x 0,75 shielded)	2 x 15 m.
<i>Signal cable (from reference meter to control panel).</i>			
Cu		3 x 0.5 shielded.	250 m.

Optional Cables:

Wire material	Recommended cable type	Numbers of wires x cross-section [mm ²]	Recommended max. length
<i>Power cable (from fuse outlet to heat pump(s)).</i>			
Cu		5 x 2.5	100 m.
<i>Control cable (from control panel to heat pump(s)).</i>			
Cu		3 x 1.5	100 m.

Connecting the consumption meter to the buildings electrical supply - XRGI 15G

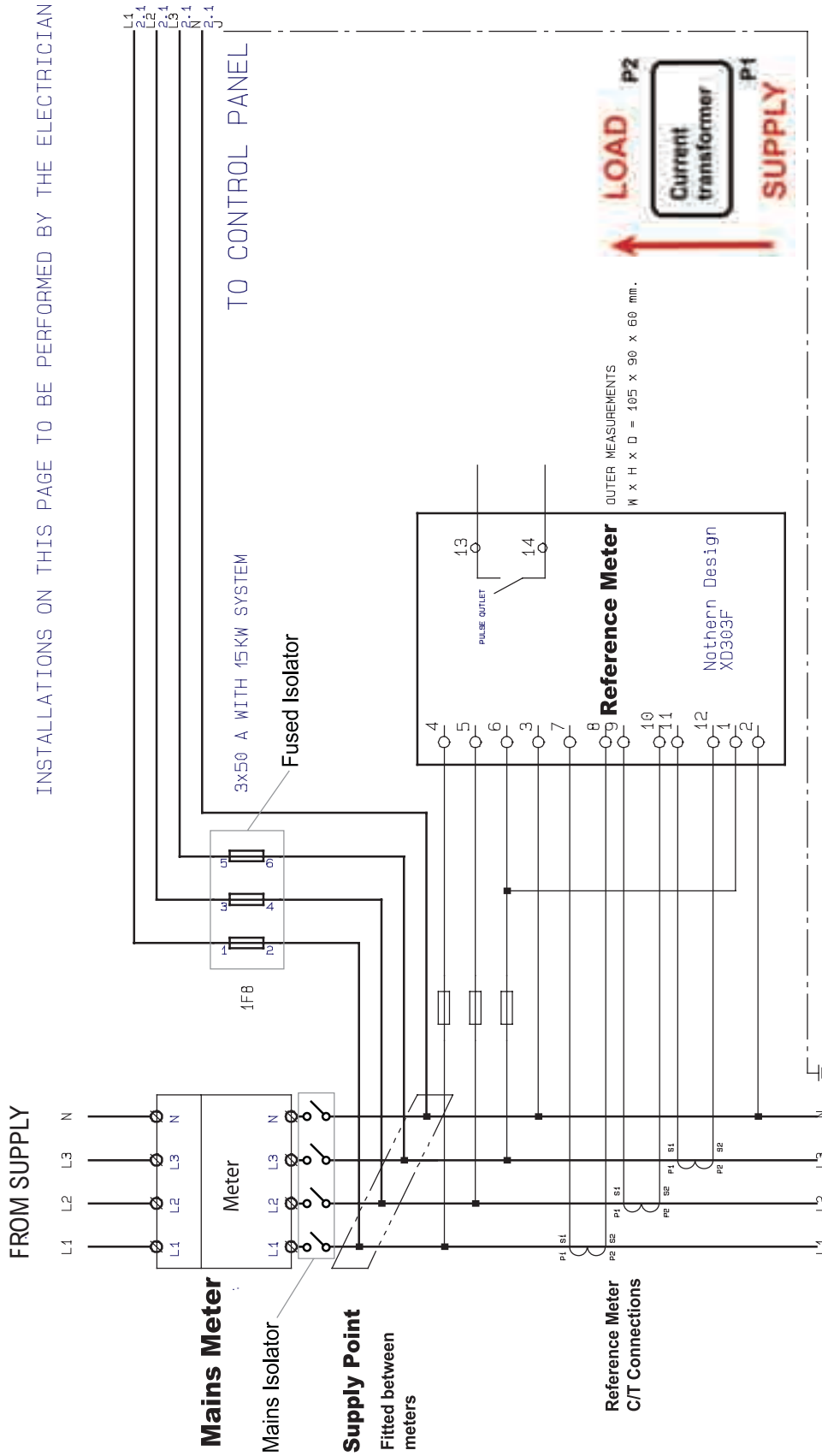

**To Electrical
Distribution Board**

Connecting the consumption meter to the buildings electrical supply - XRGI 17D

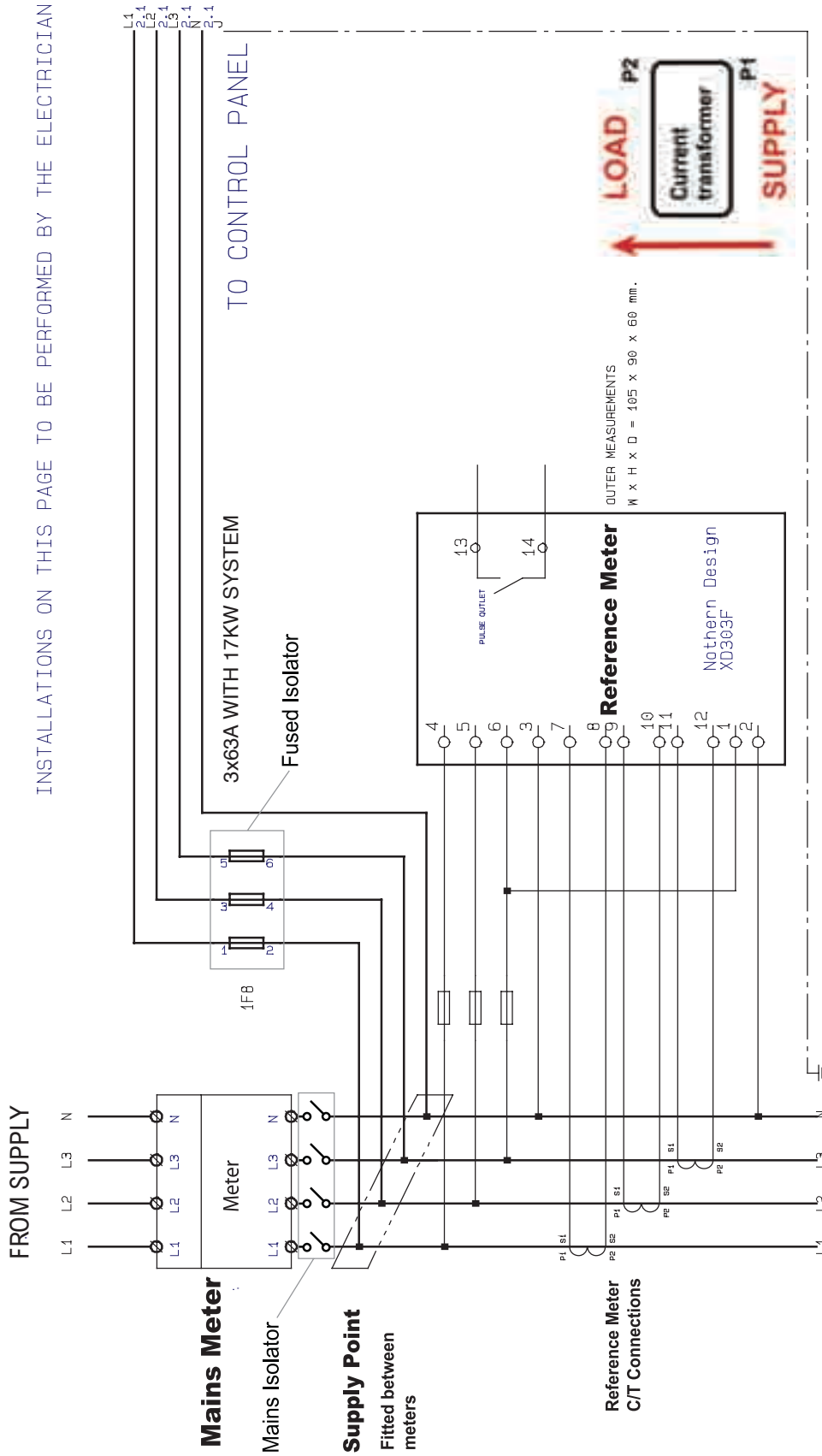

**To Electrical
Distribution Board**

Power Unit - XRGI 15G

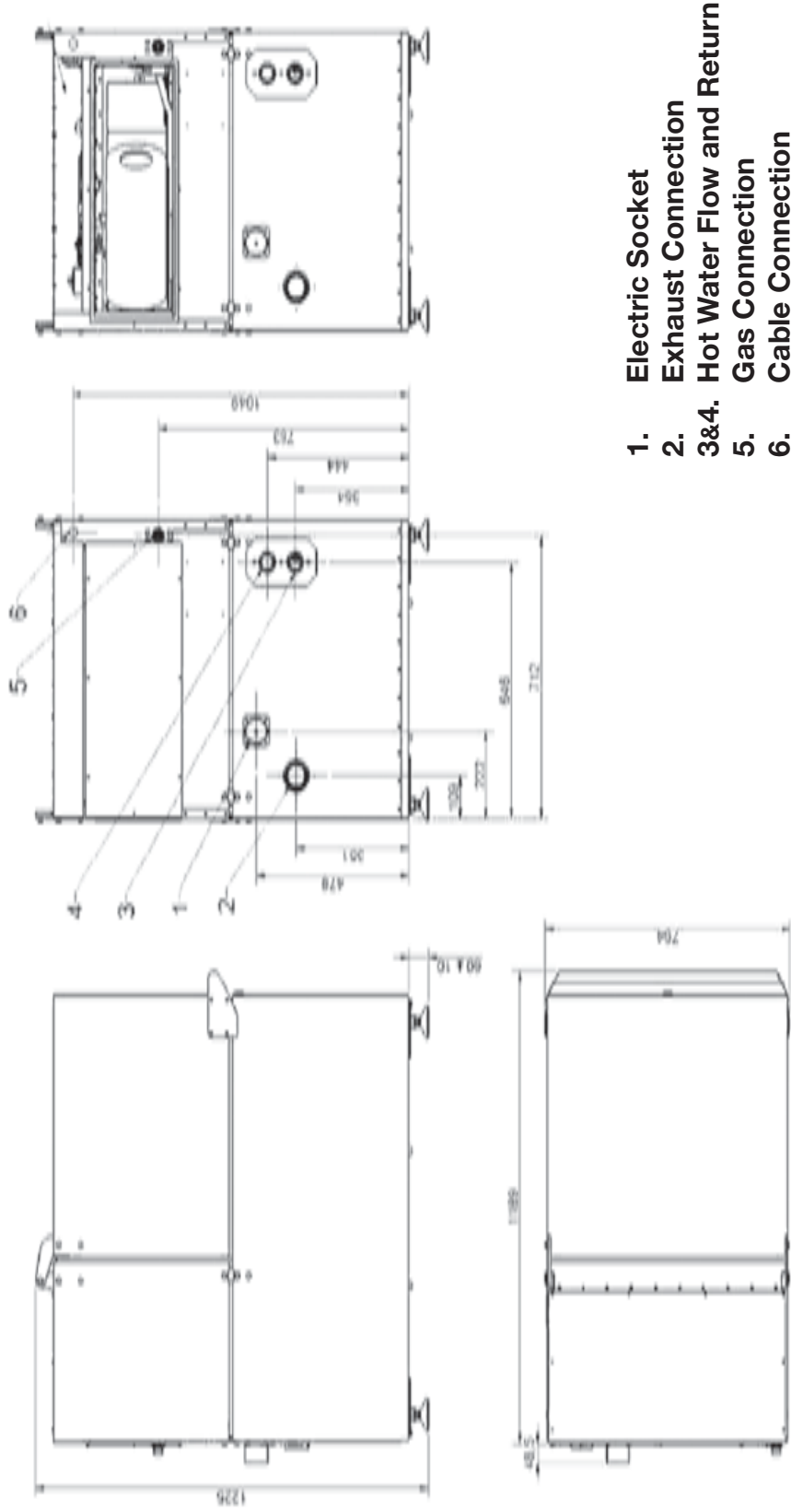

- 1. Electric Socket
- 2. Exhaust Connection
- 3&4. Hot Water Flow and Return
- 5. Gas Connection
- 6. Cable Connection

Power Unit - XRGI 17D

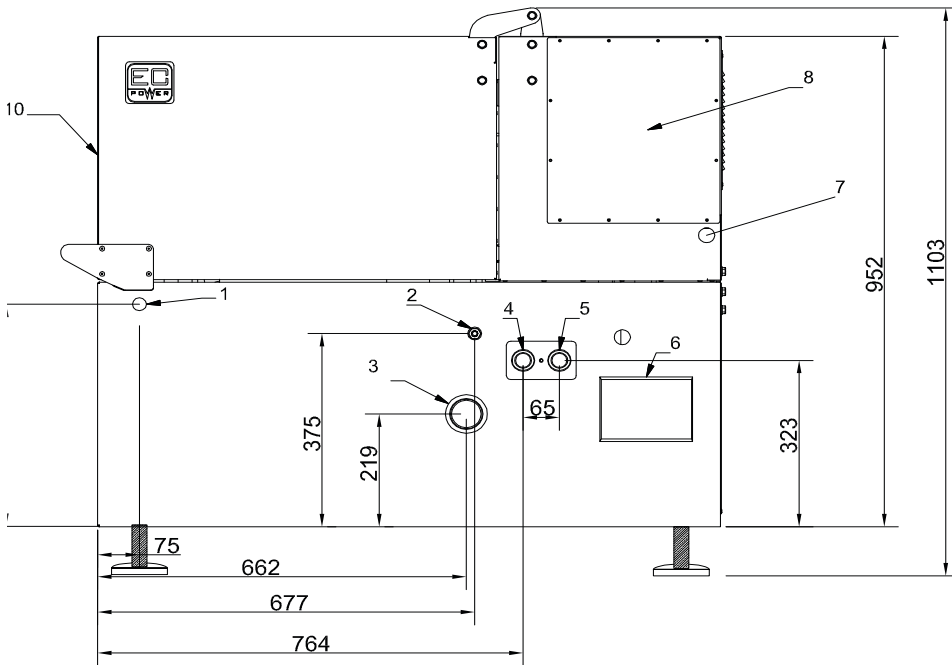

- 1. Diesel, flow
- 2. Lubrication Oil
hose connection
- 3. Exhaust 2" thread
- 4. Motor circuit, flow
- 5. Motor circuit, return
- 6. Power/production cable
connection box
- 7. Control cable
- 8. Cover, air filter
- 9. Cover, cable connections
- 10. Cabinet door

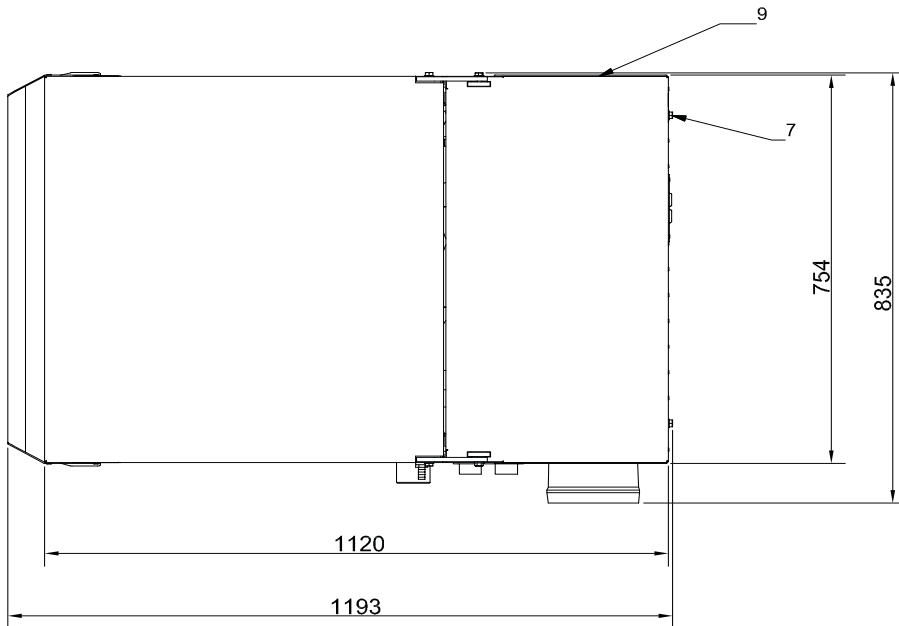

Control Panel

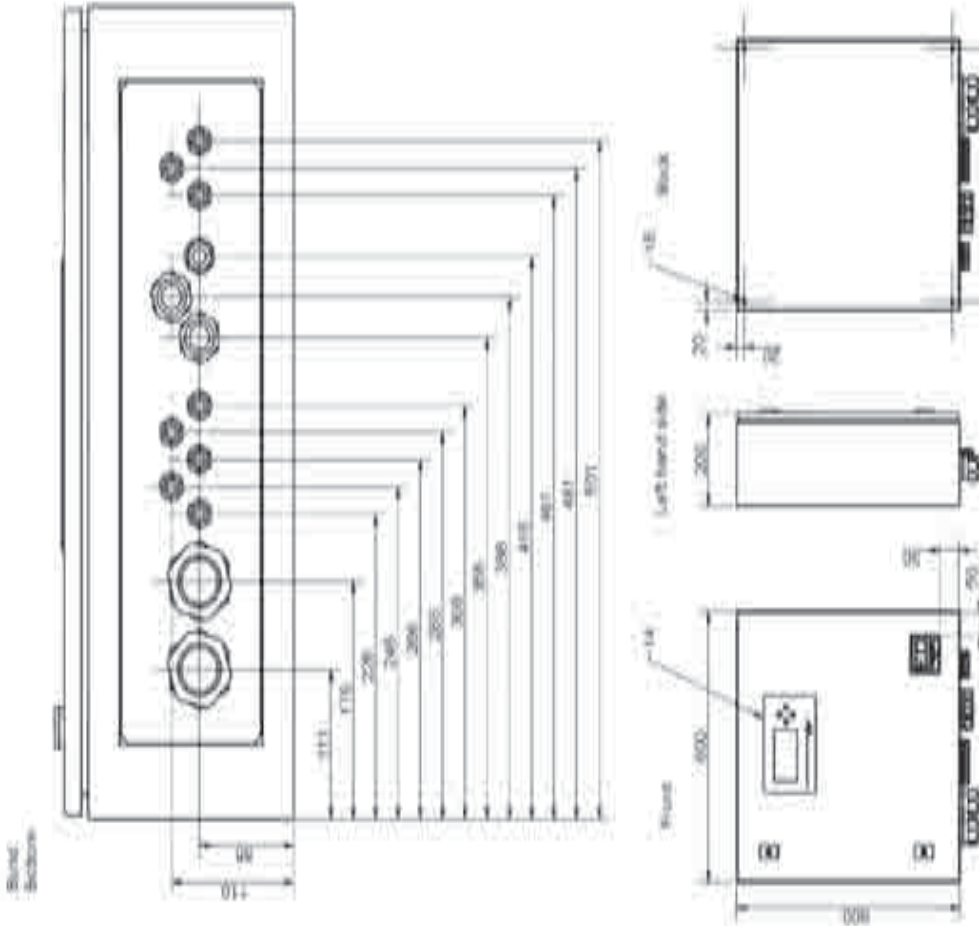
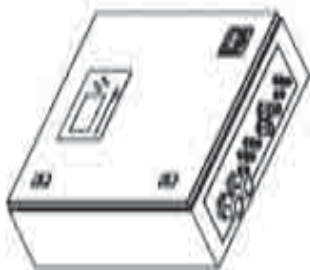

Q40 Heat Distributor

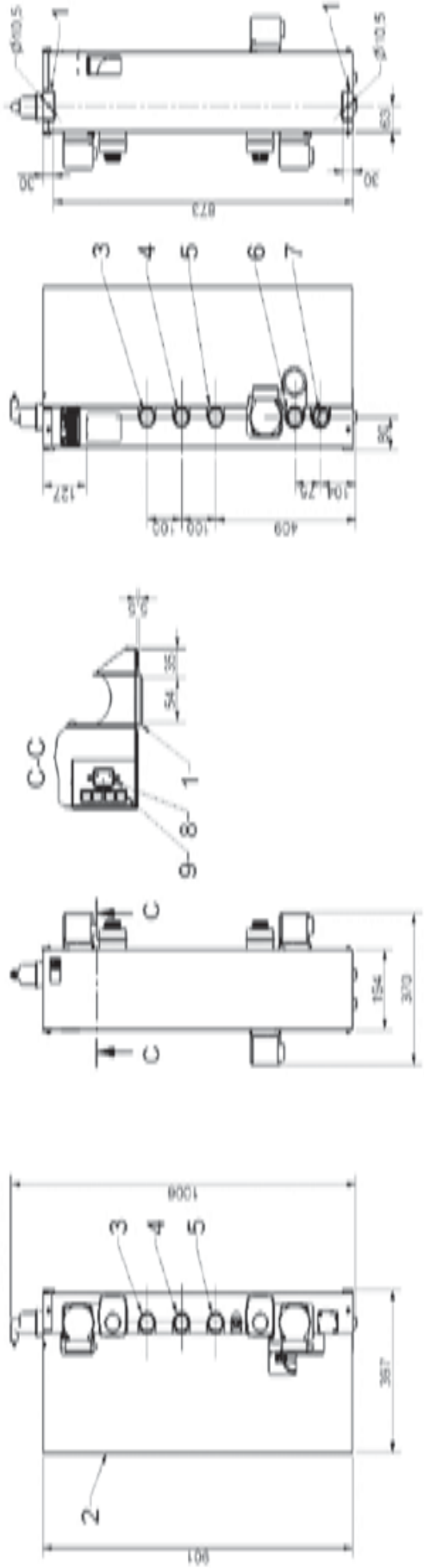

- | | |
|---|---|
| <ol style="list-style-type: none"> 1. Mounting Plate 2. Shield 3. Flow 4. Top of Heat Storage 5. Return and bottom of Heat Storage | <ol style="list-style-type: none"> 6. Return, Power Unit 7. Flow, Power Unit 8. Mains Plug 9. Q-Network |
|---|---|

Storage Tank

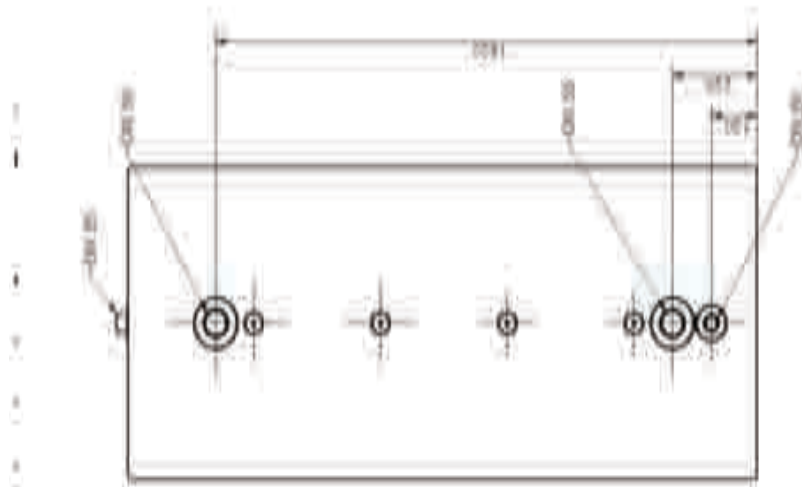
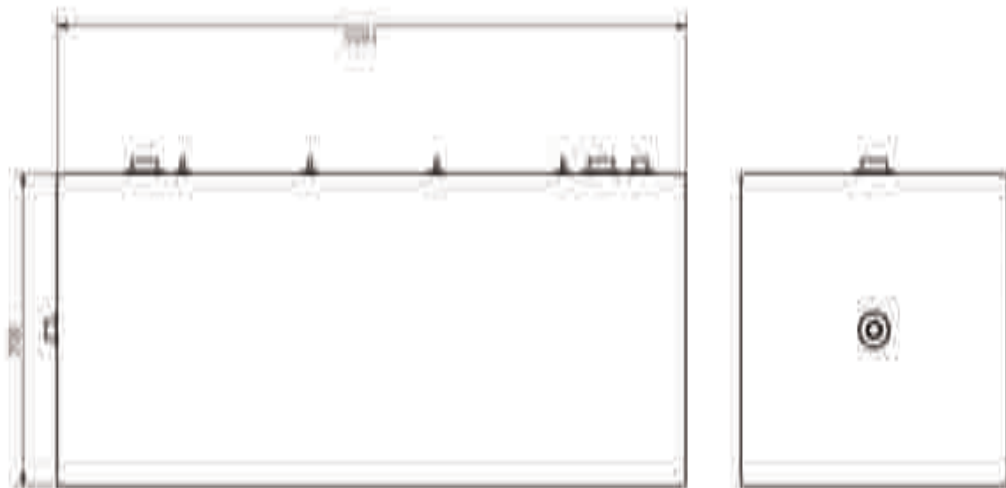
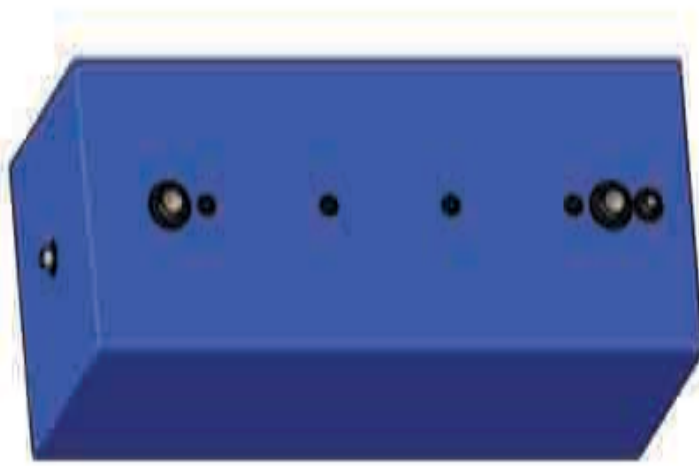



EC Power UK Ltd

**Unit 9,
Bowling Hill Business Park,
Chipping Sodbury,
Bristol
BS37 6JL
United Kingdom**

**T 01454 285060
F 01454 323034
info@ecpower.co.uk
www.ecpower.co.uk**