

# Frese Optima – Pressure independent two port modulating control & balancing valve

## Application

The innovative design of Frese Optima combines an externally adjustable tamper resistant automatic balancing valve, a differential pressure control valve and a full authority modulating control valve. The maximum flow of the Frese Optima can be adjusted once the actuator is removed according to the required design flow. With the electrical actuator mounted, the automatic balancing cartridge eliminates any flow above the design flow whilst the control component retains authority and full-stroke modulation at all times.

Due to the automatic balancing and full authority features, the Frese Optima can be used for high precision temperature control on heating and cooling units such as fan-coils, air-handling units and other terminal units.

Furthermore, the Frese Optima combines all necessary features to ease the work of designers and installers: flushing is possible due to the cartridge solution selected for the automatic balancing part of the valve; the wide (up to 400kPa) differential pressure range meets the requirements of most applications; the compact design and the user-friendly presetting unit guarantee easy installation and commissioning.

## Benefits

### Design

- Less time to define the necessary equipment for a hydraulic balanced system (only flow data are required)
- No need to calculate valve authority
- Security that the specified flow is also the actual flow
- Flexibility if the system is modified after the initial installation

### Installation

- No further regulating valves required in the distribution pipework when Frese Optima is installed at terminals.
- Total number of valves minimized due to the 3-in-1 design
- Minimized commissioning time due to automatic balancing of the system
- Removable cartridge solution simplifies flushing procedure
- No minimum straight pipe lengths required before or after the valve.

### Operation

- High comfort for the end-users due to high precision temperature control
- Longer life due to less movements of the actuator
- Less energy consumption due to faster response and increased system stability



## Advantages

- The presetting function has no impact on the stroke; Full stroke modulation at all times, regardless the preset flow.
- The constant differential pressure across the modulating control component guarantees 100% authority.
- Automatic balancing eliminates overflows, regardless of fluctuating pressure conditions in the system
- Flushing through the valve is possible due to the removable cartridge feature
- Electrical actuator 0-10 V, normally closed
- Differential pressure operating range up to 400 kPa
- High flows with minimal required differential pressure due to advanced design of the valve
- More accurate control due to long 5mm stroke
- Higher presetting precision due to stepless analogue scale

**Frese Optima - Pressure independent two port modulating control & balancing valve**

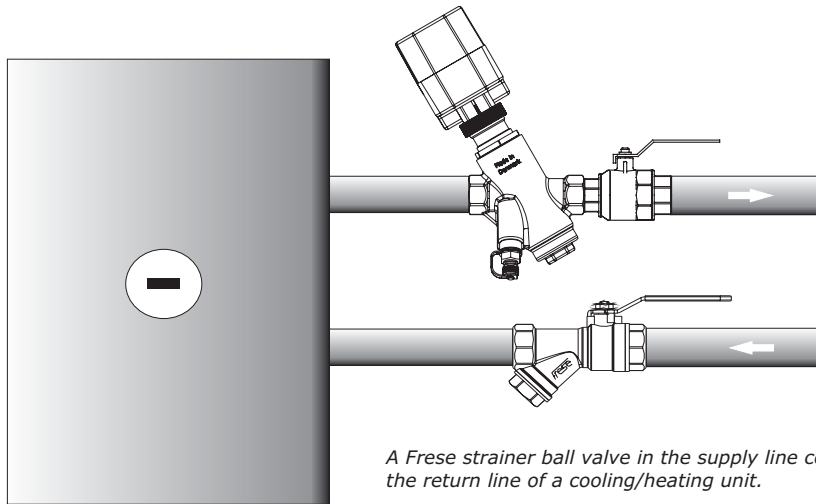

*A Frese strainer ball valve in the supply line combined with a Frese Optima in the return line of a cooling/heating unit.*

**Application**

The Frese Optima can be used in many different heating/cooling applications when automatic balancing and precise temperature control is required.

**Design**

The design of Frese Optima combines high performance with small size and compact construction. The main components of the valve are:

- the automatic balancing cartridge
- the modulating control component
- the presetting scale (not accessible when the actuator is mounted)
- the P/T plugs (optional)
- the electrical actuator (0-10V)

**Function**

The Frese Optima is delivered with a 'First Open' plastic component allowing the flow to pass through the valve before the actuator is installed. The First Open and cartridge features allow flushing through the valve before commissioning the system. After flushing, the balancing cartridge can be reinserted into the valve and the First Open component can be discarded allowing the user to adjust the presetting dial to the design flow. The presetting of the dial is user-friendly requiring only a simple flow vs. presetting graph. Once the flow is set, the actuator can be mounted making the presetting tamper resistant and the valve ready to operate.

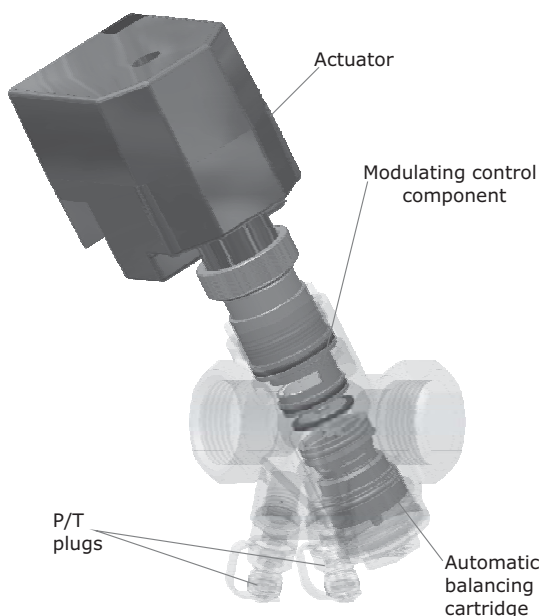

**Frese Optima – Pressure independent two port modulating control & balancing valve**

**Operation principle**

The innovative design of Frese Optima introduces a modulating control component that retains 100% authority at all times.

With the Frese Optima, there are two independent movements for the presetting and the modulating function. During presetting, the inlet area moves radially without interfering with the length of the stroke. During modulating, the inlet area moves linearly taking advantage of the full stroke. In the example below, the flow is modulated throughout the full range from 10 to 0V regardless of the preset flow (i.e. 625 l/h or 300 l/h).

Whilst the control component provides proportional modulation irrespective of the preset flow, the automatic balancing cartridge guarantees that the flow will never exceed the maximum preset flow. Regardless of pressure fluctuations in the system, the maximum flow is kept constant up to a maximum differential pressure of 400kPa.

**Flow rate vs. Differential Pressure**

(Preset flow: 625 l/h, 300 l/h)

Flow (l/h)

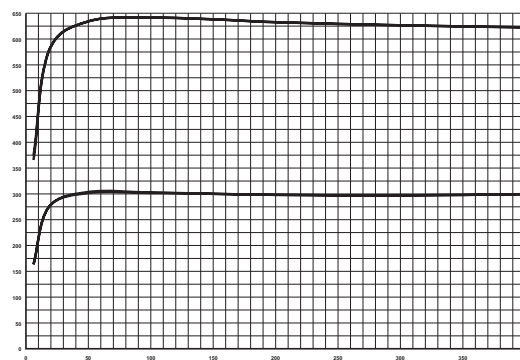

Differential Pressure (kPa)

**Flow rate vs. Voltage**

(Preset flow: 625 l/h, 300 l/h)

Voltage (V)

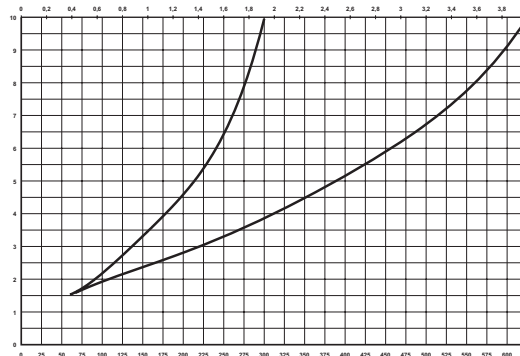

pre-setting

Flow (l/h)

**Flow rate vs. Differential Pressure**

(Voltage: 10V, 6V, 3V)

Flow (l/h)

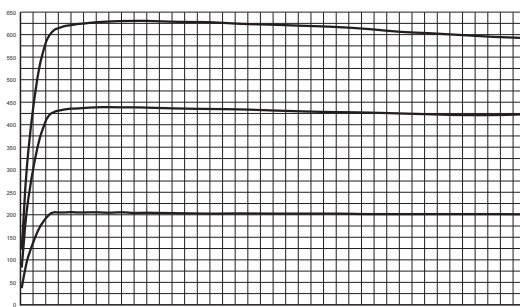

10V

6V

3V

Differential Pressure (kPa)

## Frese Optima - Pressure independent two port modulating control & balancing valve

### Technical Data

#### Valve

Material: DR, Dezincification Resistant Brass  
 O-rings: EPDM  
 Pressure class: PN 25  
 Max. differential pressure: 400 kPa  
 Medium temperature: 0°C to 120°C

#### Actuator

Characteristics: Electrical, modulating, normally closed  
 Protection class: IP 44  
 Power supply: 24 V AC ±15%  
 Frequency: 50/60 Hz  
 Power consumption: 6 W  
 Control signal: 0-10 V DC, 1mA  
 Actuating force: 400 N  
 Stroke: 5.5 mm  
 Running time: 121 s  
 Ambient operating conditions: 0°C to 50°C  
 Manual operation: 5mm hexagonal key  
 Cable length: 1m  
 Weight: 400 g  
 CE compliance: 89/336/EEC, 93/68/EEC,

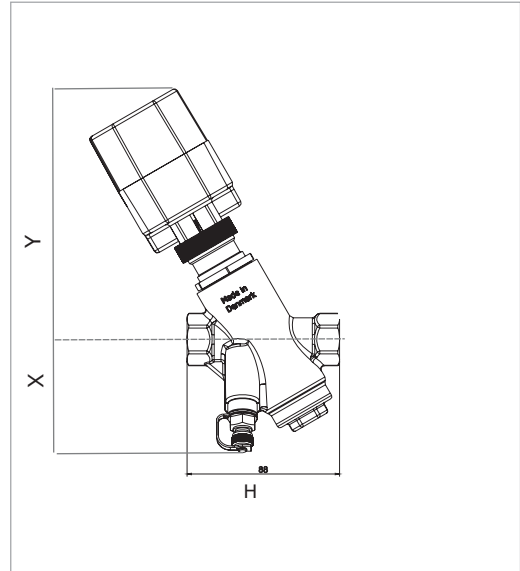

#### Electrical connection

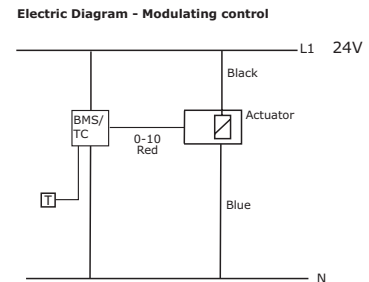

### Product Range

#### With P/T plugs

Dimensions		High Flow		Low Flow			Weight	H	X	Y
Fem/Fem	Product No.	Flow* (l/h)	Min. ΔP(kPa)	Product No.	Flow (l/h)	Min. ΔP(kPa)	kg	mm	mm	mm
DN15	53-1004	200-1500	18	53-1000	75-500	16	0,898	88	65	145
DN20	53-1005	200-2000	22	53-1001	100-900	16	0,908	88	66	145
DN25	53-1006	200-2000	22	53-1002	200-1500	16	0,998	92	66	145
DN32	53-1003	500-3000	18				1,518	128	72	152

\* (example: for high flow DN15, the maximum flow can be set between 200 and 1500l/h, according to design specifications)

#### Without P/T plugs

Dimensions		High Flow		Low Flow			Weight	H	X	Y
Fem/Fem	Product No.	Flow* (l/h)	Min. ΔP(kPa)	Product No.	Flow (l/h)	Min. ΔP(kPa)	kg	mm	mm	mm
DN15	53-1024	200-1500	18	53-1020	75-500	16	0,898	88	65	145
DN20	53-1025	200-2000	22	53-1021	100-900	16	0,908	88	66	145
DN25	53-1026	200-2000	22	53-1022	200-1500	16	0,998	92	66	145
DN32	53-1023	500-3000	18				1,518	128	72	152

Modulating actuator 24V /0-10V)	53-1040
---------------------------------	---------

The pipe system shall be properly ventilated to avoid risk of air-pockets.  
 Glycolic mixtures in any solution are applicable (both ethylene and propylene).  
 Frese A/S can accept no responsibility if another actuator is used instead of the Frese actuator.

**Frese Optima – Pressure independent two port modulating control & balancing valve**

**Frese Optima DN 15 Low flow**

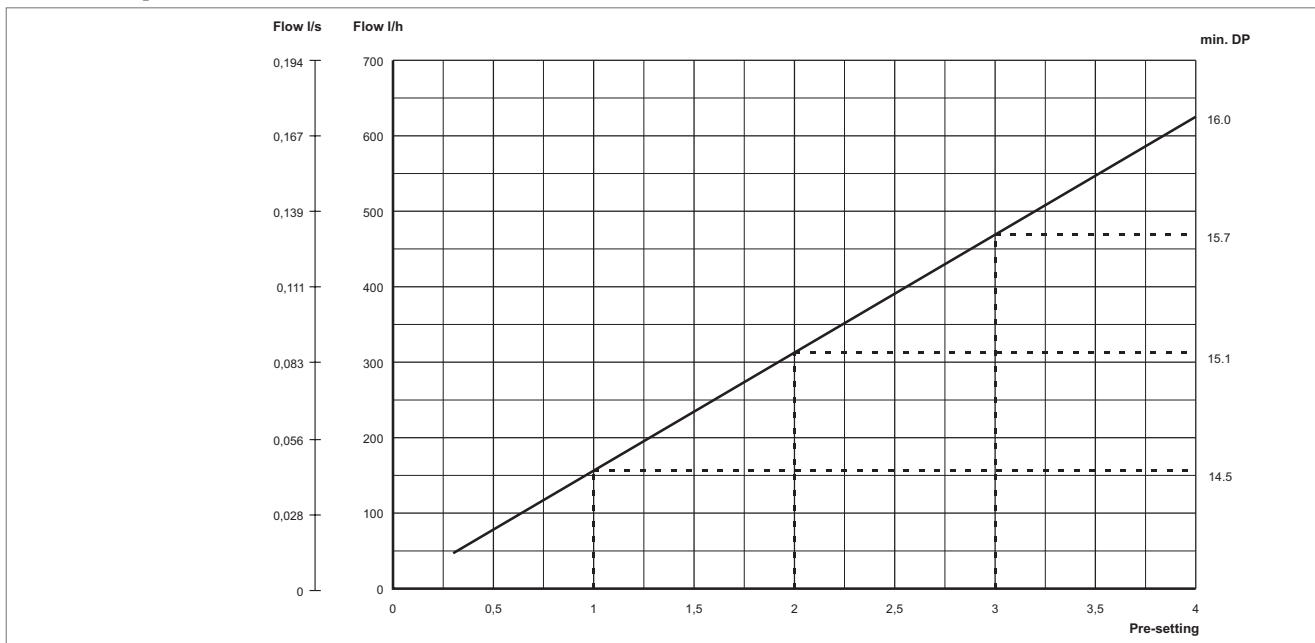

**Frese Optima D15 High Flow**

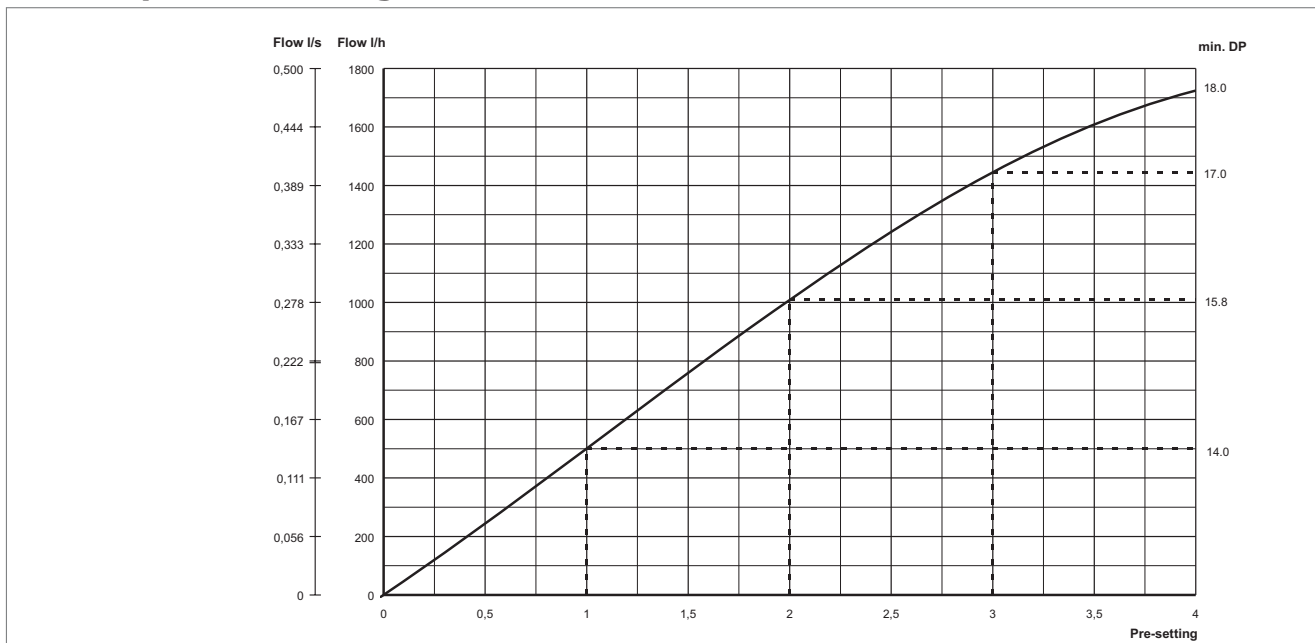

**Frese Optima - Pressure independent two port modulating control & balancing valve**

**Frese Optima DN 20 Low Flow**

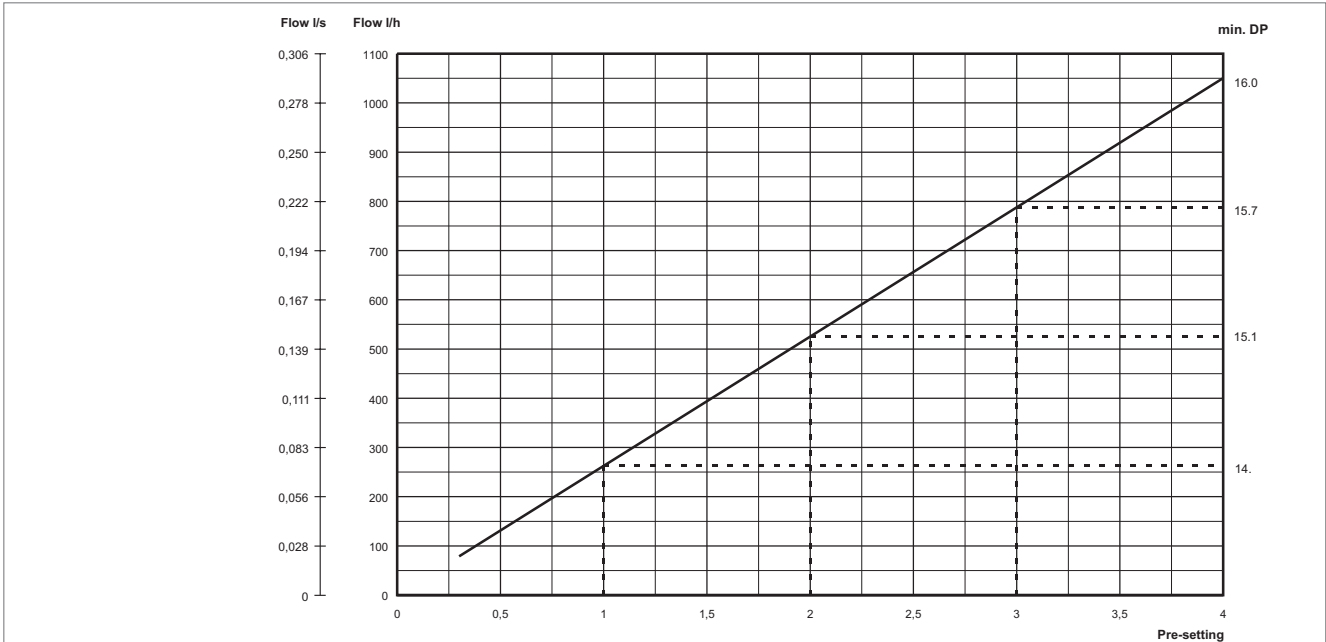

**Frese Optima DN 20 High Flow**

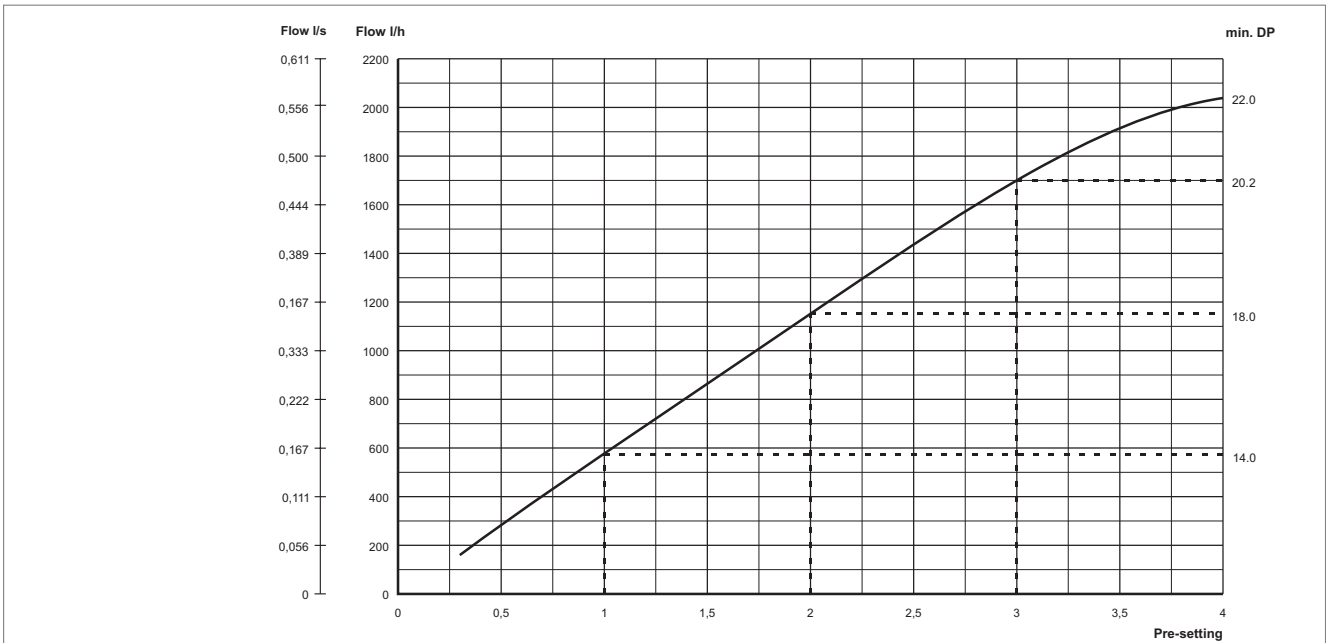

# Frese Optima – Pressure independent two port modulating control & balancing valve

## Frese Optima DN 25 Low flow

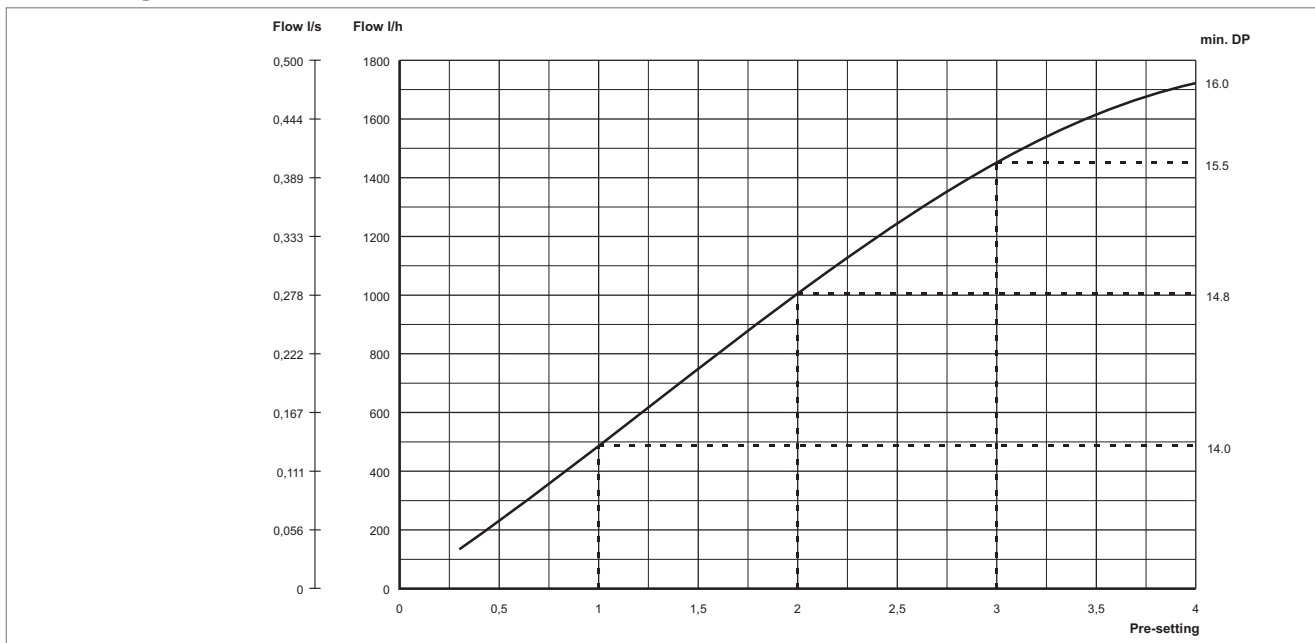

## Frese Optima D25 High Flow

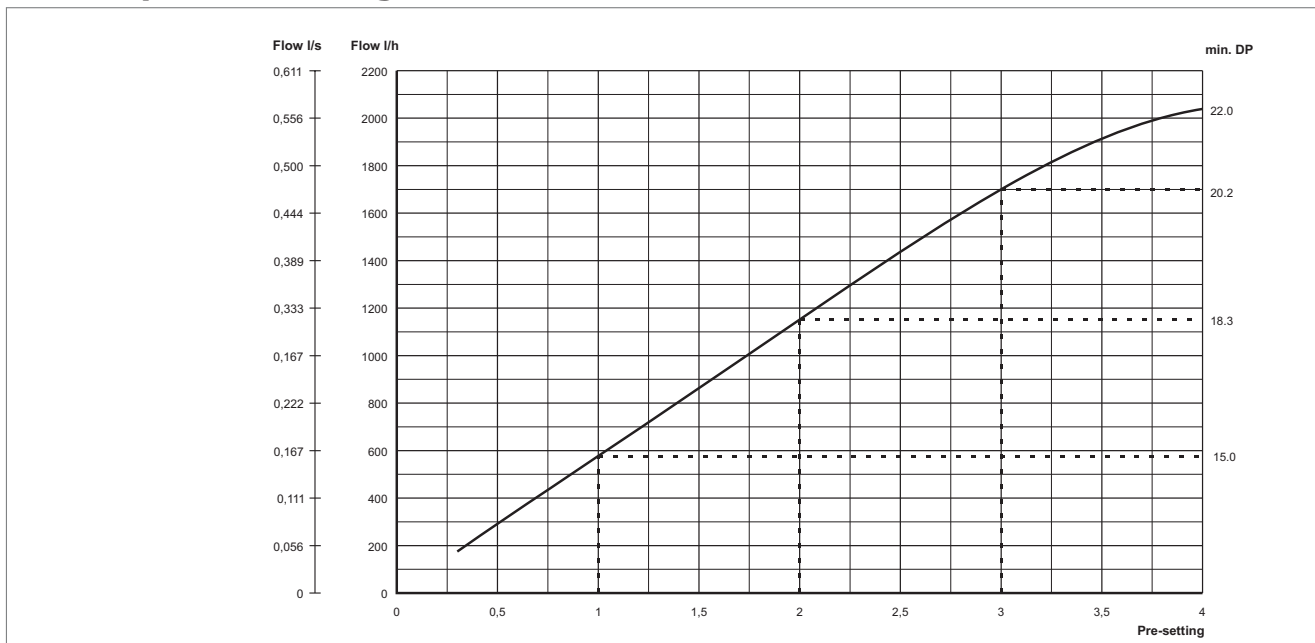

**Frese Optima - Pressure independent two port modulating control & balancing valve**

**Frese Optima DN 32 Flowgraph**

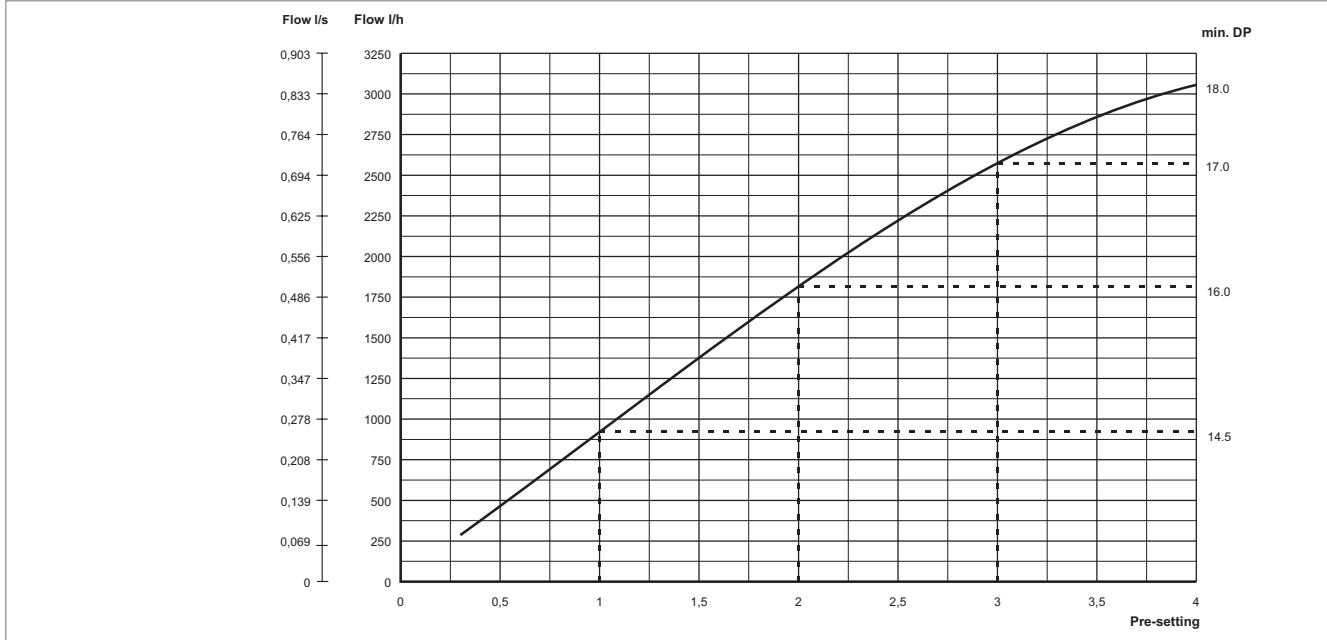

**Specification text**

The actuated valve shall operate by means of an automatic balancing cartridge that can be removed without dismantling the valve. The presetting of the valve shall not influence the length of the stroke. The pressure class shall be PN25. The differential pressure operating range shall be up to 400kPa. The valve shall operate by means of an electrical modulating actuator.

Frese A/S assumes no responsibility for errors, if any, in catalogues, brochures, and other printed matter. Frese A/S reserves the right to modify its products without prior notice, including already ordered products, if this can occur without changing already stated specifications. All registered trade marks in this material are the property of Frese A/S. All rights reserved.

Frese A/S  
 Sorøvej 8  
 DK - 4200 Slagelse  
 Tel +45 58 56 00 00  
 Fax +45 58 56 00 91  
 frese@frese.dk  
 www.frese.eu